



160121/19:40 (printdate/time)

**USER MANUAL
(IMPLEMENTATION GUIDE)**

UN/EDIFACT STOWAGE MESSAGE

**MOVINS
For
Rail**

Version 0.1

DRAFT VERSION

**THIS MANUAL IS INTENDED TO BE STUDIED AND DISCUSSED
BY SMDG MEMBERS.**

USE OF THIS MANUAL IS ENTIRELY AT YOUR OWN RISK.

December 2008 - April 2009

Version : 0.1
Date : 12/2008
Source : SMDG User Group for Shipping Lines and Container Terminals

© SMDG

Information in this document is subject to change without notice.

SMDG claims full copyright to this manual and its contents, however, the manual may be copied and used by anyone, without the consent of SMDG.

It is not allowed to change the contents of this manual!

DRAFT VERSION

CONTENTS

0.	INTRODUCTION	iii
1.	ADDRESSES	iv
2.	GENERAL	v
3.	VERSIONS	vii
4.	DESCRIPTION	1
5.	SPECIAL USER GUIDELINES	35
6.	EXAMPLES	36
7.	EXAMPLE MESSAGES	47
8.	MESSAGE STRUCTURE DIAGRAM	49
9.	SEGMENT DIRECTORY	51
10.	SMDG EDI-UNDERSTANDING	61

DRAFT VERSION

This page is left blank intentionally

DRAFT VERSION

0. INTRODUCTION

The instructions are valid for the "UN/EDIFACT UNITED NATIONS STANDARD MESSAGE (UNSM) DRAFT STOWAGE INSTRUCTION MESSAGE" (mnemonic MOVINS), as designed by the SMDG (User Group for Shipping Lines and Container Terminals).

The instructions in this manual are valid for transport of containers by **RAIL**.

This manual is intended for use by terminal operators, rail operators, etc.

This "User Manual" (or "Implementation Guide") version 0.1 was developed in 2008 and 2009 by the **User Group for Shipping Lines and Container Terminals SMDG**.

The **SMDG** is a "Pan European User Group" under the auspices of the **Western European Edifact Board (WEEB)**.

SMDG claims full copyright to this manual and its contents, however, the manual may be copied and used by anyone, without the consent of the SMDG.

It is not allowed to change the contents of this manual!

DRAFT VERSION

1. ADDRESSES

Any remarks, comments or questions can be addressed to the following address:

SMDG Secretariat
Kamerlingh Onnesweg 10c
2991 XL Barendrecht
The Netherlands
Phone: 31-10-2941100
Fax: 31-10-2941105

or to any active member of the SMDG.

DRAFT VERSION

2. GENERAL

The EDIFACT Stowage instruction "MOVINS" will be used to transmit the train composition information about Rail loading activities on a specified train from the operator or owner of the train to any party involved with the operation on this train at a certain place.

The Principle

The handling instructions given in the "MOVINS" message will apply to the information available in the planning system of the terminal. The details of the train, like train id, wagon numbers and container position numbers on the wagon, should be known by the planning system of the terminal.

This message is to be transmitted in general from the operator/owner of a MoT or a stowage centre to e.g. the Rail-terminal operator in the receiving terminal. Generally, information transmitted in a "MOVINS" message applies to the data previously received in a "BAPLIE" message. The results of the operation optionally will be reflected in a new BAPLIE message.

The receiver of this message is able and may extract information from the message and incorporate respectively build up a new Bayplan message "BAPLIE" as the message structure of "MOVINS" is based on the "BAPLIE" message. The sequence of related segments such as DTM, RFF, NAD followed by segments TDT/LOC/DTM of group 1, is the same as in the "BAPLIE" message.

Conventions

In this document a data element will be identified by the lowercase letter "e" followed by its element number (example: e8053). A data element within a composite will be identified by the lowercase letter "c" followed by the composite number followed by a full stop "." followed by the lowercase letter "e" followed by the element number (example: c237.e8260).

Immediately below the segment tags and data element identification the usage of same will be mentioned as follows:

'M' = mandatory:	The segment or data element is mandatory and must be given.
'R' = required:	The segment or data element is conditional but MUST be used anyway.
'D' = dependent:	The segment or data element is conditional and its use depends on some condition. This condition must be clarified in the description.
'A' = recommended:	The segment or data element is conditional and its use is recommended.
'O' = optional:	The segment or data element is conditional and its use is optional at the discretion of the sender.
'X' = not used:	The segment must not be used.

Next to the usage indicator the official format of the field will be given, i.e. a4 or an..15. The description may further limit the format of the field, f.e. a field with a format an..17 may be limited to an12 by its description.

If composites or data-elements are repeated within a segment, respectively a composite, the occurrences of the composites or data-elements can be indicated by its sequence number within the segment or composite between brackets, e.g. "(1)" being the first occurrence of the composite or data-element within the segment. If its occurrence within the segment or composite is of no relevance then the sequence number will not be mentioned. If the sequence numbers are mentioned, but not all of them (e.g. only 2 out of 5 occurrences are described), then the remaining occurrences may NOT be used, unless agreed otherwise between partners.

Data elements within the segments that are not mentioned here will not be used,

DRAFT VERSION

resp. should not contain important information, since they will probably not be seen by the recipient, unless agreed otherwise.

SMDG recommends to use only data elements, qualifiers and codes described in this manual. If partners agree to use additional data elements, qualifiers and codes, not described in this manual, then specific and detailed agreement about those data elements, qualifiers and codes should be made!

Optional data elements may be omitted, unless specifically made compulsory by this manual (Indicator "R" = required), or unless agreed otherwise between partners.

In no case neither mandatory segments according to the Stowage Message Documentation "MOVINS" nor mandatory composites or data elements according to the relevant Segment Directory may be omitted.

DRAFT VERSION

3. VERSIONS

Data elements, composites and segments of the **UN/Edifact draft directory D.95B** are used in this manual.

Codes and qualifiers used, are according to **UN/EDIFACT Directory D.95B Code List**.

In some occasions, however, the required code or qualifier could not be found in the code list. In such cases a temporary code was assigned, awaiting the final code allocation from the UN/Edifact Board Code commission.

Also in some cases small amendments to the message structure were necessary. This manual anticipates on the approval of the respective CR (Change Request) or DMR (Data Maintenance Request) by the UN/Edifact Board. The structure of the message, as given in chapter 7, was agreed as such by the members of SMDG and will be implemented accordingly.

The Movins implementation guideline for container vessels, version 2.0.4, has been used as a template for this guideline for rail.

DRAFT VERSION

This page is left blank intentionally.

DRAFT VERSION

4. DESCRIPTION**UNB (M1) INTERCHANGE HEADER**

+

s001.e0001 Syntax Identifier: Always "UNOA", indicating the use
(M a4) of level "A" character set.

:

s001.e0002 Syntax Version Number: Always "1".
(M a1)

+

s002.e0004 Sender Identification: Name code of the sender of the
(M an..35) interchange (message). To be agreed between partners.

+

s003.e0010 Recipient Identification: Name code of the recipient of
(M an..35) the interchange (message). To be agreed between partners.

+

s004.e0017 Date of preparation: Preparation date of the interchange
(M n6) (message).

:

s004.e0019 Time of preparation: Preparation time of the interchange
(M n4) (message).

+

e0020 Interchange control reference: A reference allocated by
(M an..14) the sender, uniquely identifying an interchange. This reference must
also be transmitted in the Interchange Trailer segment UNZ.

+

+

+

+

+

e0032 Communications Agreement Id: A code identifying the
(A an..35) shipping line of the vessel (BIC, SCAC or mutually agreed).
N.B. This code enables proper routing of the message by the recipient.

,

DRAFT VERSION

UNH (M1) MESSAGE HEADER

+

e0062 Message reference number: A reference allocated by the sender,
(M an..14) uniquely identifying a message. This reference must also be transmitted
in the Message Trailer segment UNT.

+

s009.e0065 Message Type Identifier: The name of the UNSM or standard
(M an..6) EDIFACT message. In this case always "MOVINS".

:

s009.e0052 Message Type Version Number: The version number of the message.
(M an..3) See EDIFACT documentation. At this moment the version is "D".

:

s009.e0054 Message Type Release Number: The release number of the message.
(M an..3) See EDIFACT documentation. At this moment the release number is
"95B".

:

s009.e0051 Controlling Agency: The code of the controlling agency. For
(M an..2) this message the controlling agency is "UN".

:

s009.e0057 Association Assigned Code: The applicable SMDG User Manual version
(R an..6) number. For this manual always: "SMDG20". This will enable the recipient
of the message to translate the message correctly, even if older
versions are still in use.

,

DRAFT VERSION

BGM (M1) BEGINNING OF MESSAGE

+

c002.e1001 Document/Message Name, coded. Code indicating which type of MOVINS this concerns.
Allowed code: 650 = Handling order (Rail Transport).

Note:

A similar code will be added to the User Guide for MOVINS for container vessels in order to align this data element with each other.

Important warning:

If this data element remains empty the recipient of the message may erroneously decide that the message is a MOVINS for container vessels and not for rail!

+

e1004 Document/Message Number: Reference allocated by the sender individually, taken from the application.
(R an..35)

+

e1225 Message Function, Coded: Code indicating the function of the message. Acceptable codes are:
(R an..3)
"2" = Add. Add to previous message.
"3" = Delete. Delete from previous message.
"4" = Change. Message with changes on previous message.
"5" = Replace. Message replacing a previous one.
"9" = Original. First or basic message.
"22" = Final. The final message in a series of MOVINS messages.

,

Remarks: In principle only original messages (code "9") are allowed. The other codes may be used after prior agreement between sender and recipient.

DRAFT VERSION

DTM (M1) DATE/TIME/PERIOD

+

c507.e2005 Date/Time/Period Qualifier: Code "137" (Document/Message
(M an..3) date/Time)

:

c507.e2380 Date/Time/Period: Date or date/time of compiling the message.
(R an..35)

:

c507.e2379 Date/Time/Period Format Qualifier: Allowed qualifiers:
(R an..3) "101" = YYMMDD
"201" = YYMMDDHHMM
"301" = YYMMDDHHMMZZZ ("ZZZ" = Timezone, e.g. "GMT" or other)

'

DRAFT VERSION

RFF (X) REFERENCE

This segment not to be used.

DRAFT VERSION

NAD (X) NAME AND ADDRESS

This segment is not to be used.

DRAFT VERSION

Group **grp1** (M1) TDT - LOC - DTM - RFF - FTX.

TDT (M1) DETAILS OF TRANSPORT (grp1)

+

e8051 Transport Stage Qualifier: Code "20" (Main Carriage)
(M an..3)

+

e8028 Conveyance Reference Number: Train voyage number as
(R an..17) assigned by the Operating Rail Carrier or his agent.

+

+

+

c040.e3127 Carrier Identification: Carrier name, coded. Codes
(R an..17) to be agreed or standard carrier alpha code (SCAC).

:

c040.e1131 Code List Qualifier: Code "172" (Carrier Code)
(R an..3)

:

c040.e3055 Code list responsible agency, coded. Allowed codes:
(R an..3) "20" = BIC (Bureau International des Containeurs)
"166" = US National Motor Freight Classification Association
(SCAC)
"ZZZ" = Mutually agreed.

+

+

+

c222.e8213 Id of Means of Transport Identification. Block train
identification code: Mutually agreed train code.

(R an..9)

:

c222.e1131 Code List Qualifier: Allowed qualifiers:
(R an..3) "ZZZ" = Mutually agreed

:

c222.e3055 Code list responsible agency, coded. Allowed code:
(R an..3) "ZZZ" = Mutually defined. To be used in all other cases.

:

c222.e8212 Id. of means of transport: Block train name, if required.
(R an..35)

:

c222.e8453 Nationality of Means of Transport: Coded according to UN-coun-
(R an..3) trycode (ISO 3166).

DRAFT VERSION

DRAFT VERSION

LOC (M99) PLACE/LOCATION IDENTIFICATION (grp1)

+

e3227 Place/Location Qualifier: Allowed qualifiers:
 (M an..3) "5" = Place of Departure
 "61" = Next port of call
 "92" = This qualifier can occur 1 to n times and is given in
 sequence of the rotation.

+

c517.e3225 Place/Location Identification: Location code of the actual
 (R AN..17) place of departure (normally the sender of the message). If possible,
 UN-Locodes of 5 characters according to UN recommendation no.16. must
 be used.

:

c517.e1131 Code list qualifier. Allowed qualifiers
 (R an..3) "139" = Port.

:

c517.e3055 Code list responsible agency, coded. Allowed codes:
 (R an..3) "112" = US, US Census Bureau, Schedule D for U S location schedule
 K for foreign port locations.
 "6" = UN/ECE - United Nations - Economic Commission for Europe.
 (UN-Locodes).

+

c519.e3223 Related place/location one identification. The ISO
 (O an..25) country code.

:

c519.e1131 Code list qualifier. Allowed qualifier:
 (O an..3) "162" = Country.

:

c519.e3055 Code list responsible agency, coded. Allowed codes:
 (O an..3) "5" = ISO

+

c553.e3233 Related place/location two identification. The
 (O an..25) state or province code, postal abbreviations.

:

c553.e1131 Code list qualifier. Allowed qualifier:
 (O an..3) "163" = Country sub-entity; state or province.

,

N.B. If locodes other than UN-locodes are used the sender must verify with the
 recipient of the message if other than UN-locodes are acceptable/ processable.
 Composites c519 and c553 are only relevant if no UN-locodes are used.

DRAFT VERSION

DTM (M99) DATE/TIME/PERIOD (grp1)

+

c507.e2005 Date/Time/Period Qualifier: Allowed qualifiers:
(M an..3) "132" = estimated date or date/time of arrival at the port-
for which handling instructions are ment.

:

c507.e2380 Date/Time/Period: Date or date/time in local time
(R an..35) when Means of Transport has arrived/departed or is expected to depart
at the senders port or is expected to arrive at the next port of call

:

c507.e2379 Date/Time/Period Format Qualifier. Allowed quali-
(R an..3) fiers:
"101" = YYMMDD
"201" = YYMMDDHHMM
"301" = YYMMDDHHMMZZZ ("ZZZ" = Timezone, e.g. "GMT" or other)

,

DRAFT VERSION

RFF (C1) REFERENCE (grp1)

+

c506.e1153 Reference Qualifier: Code "VON" (Loading Voyage
(M an..3) number, if different from the voyage number in the TDT-segment,
assigned by the Operating Carrier or his agent to the voyage of the
train).

:

c506.e1154 Reference Number: The Loading voyage number.
(R an..35)

'

DRAFT VERSION

FTX (C9) FREE TEXT (grp1)

+

e4451 Text Subject Qualifier: Allowed qualifiers:
(M an..17) "HAN" = Handling Instructions
"CLR" = Container Loading Remarks
"SIN" = Special instructions
"AAI" = General information
"ZZZ" = Mutually defined use

+

+

c108.e4440 Free Text: Description/Instructions/Remarks in plain
(M an..70) language or coded, for specific cargo/equipment. Codes, etc. to be
agreed between partners. One element with maximum field length 20
characters, unless agreed otherwise.

'

N.B. 1) This segment is not generally machine processable. Use of this segment must be agreed between partners!

N.B. 2) This segment only to be used to transmit additional shipbounded information or instructions!

This segment can be used for the following:

- a. "AAI" Description of general information, plain language or codes, as agreed between partners. Maximum 20 characters.
for example : name and telephone nr SCO planner
- b. "SIN" Additional information or instructions regarding special cargoes, equipment or breakbulk shipments.
- c. "HAN" For handling instructions the following codes are recommended:
"PLC" = Stowage is subject to pileweight
"MGM" = Minimum GM-value required

DRAFT VERSION

Group **grp2** (M9999) HAN - grp3

HAN (M1) Handling instruction (grp2)

+

c524.e4079 Handling Instruction, Coded: All codes Sequence
(M an..3) within the message must be:

- "SHI" = Shift: Indicating the cells with containers/cargo to be shifted. In general within the same bay and not via the quayarea, depending on the terminal agreement.
- "RES" = Restow: Indicating the cells with containers/cargo to be restowed. In general from one bay to another and likely via the quayarea, depending on the terminal agreement.
- "LOA" = Loading: Indicating the cells to be used for loading containers/cargo due to the given specifications.
- "COD" = Change of destination: Indicating the cells with containers of which the port of discharge has to be changed.
- "EXC" = Excess of stowage positions: Indicating the excess of cell positions due to last minut drops in relation to a "MOVINS" previously sent.
- "VOI" = Cell positions to be avoided: Indicating cell positions to be avoided due to damages, repair of cell guides, etc.

,

Principles:

The (LOA), (COD), (EXC) and (VOI) handling instructions will be indicated on train wagon positions only.

Loading instruction: The main attribute will be the port of discharge, generally resulting in a number of rail wagon positions which have to be loaded with containers /cargo for that port of discharge (destination).

For Dangerous cargo, Reefers and Specials the cell positions must be strictly followed.

The (RES) and (SHI) handling instructions can be indicated in one way. On rail wagon id combined with the rail wagon position only.

DRAFT VERSION

Group **grp3** (C9999) LOC - GID - GDS - FTX - MEA - DIM - TMP - RNG - LOC - RFF
- grp4 - grp5

LOC (M1) PLACE/LOCATION IDENTIFICATION (grp3)

+

e3227 Place/Location Qualifier: Code "147" (Rail Wagon Position)
(M an..3)

+

c517.e3225 Place/Location Identification: The sequence number of the
(R an..25) railway wagon in the train. The first wagon in the train, after the
locomotive, gets sequence number '01'. The second '02', and so on.

+

c519.e3223 Related Location One Identification: The identification
(R an..25) number of the railway wagon in the train. This is the wagon number
as painted on the wagon.

+

c553.e3233 Related Location Two Identification: The actual location of
(O an..25) the container on the railway wagon. Location number to be agreed.
Recommendation: Number each 20ft slot on the wagon, starting with
'01' from the front, which is the nearest slot to the locomotive.
The second slot gets number '02', and so on. In case of double stack
trains, the lower location gets a suffix of the letter 'a' and the
upper location gets 'b'.

In case the wagon is empty this group can still be transmitted but
this data element must NOT be used. Also the EQD group, where the
container details should be given, must not be used in such cases.

,

Remarks:

The sequence of the wagons in the train and the sequence of the containers on the
wagons will always be calculated from the front of the train, i.e. where normally
the locomotive is pulling the train.

When the train arrives the first wagon is the wagon directly behind the locomotive.
If the locomotive will then be shunted to the back of the train to pull the train
from that position to a new destination the sequence of the wagons in the train
and the containers on the wagons will be reversed and consequently the first wagon
on arrival will be the last wagon on departure.

DRAFT VERSION

GID (C1) GOODS ITEM DETAILS (grp3)+
+

c213.e7224 Number of packages. The number of packages of non
(0 an..8) containerized cargo.

:

c213.e7065 Type of packages identification. Package type for
(0 an..7) non-containerized cargo.

'

DRAFT VERSION

GDS (C1) GOODS DESCRIPTION (grp3)

+

c703.e7085 Nature of cargo, coded. Codes to be agreed between
(M an..3) partners.

'

Remarks: If this data is required, we recommend the use of the Harmonized Commodity Description and Coding System code list of cargo nature (HS). This codelist is:

"01"	=	Live animal
"06"	=	Live plant
"09"	=	Coffee
"10"	=	Wheat
"12"	=	Hay
"22"	=	Malt
"24"	=	Tobacco
"41"	=	Hide
"44"	=	Timber pack
"48"	=	Waste paper
"49"	=	News print
"52"	=	Cotton
"68"	=	Stone
"72"	=	Iron scrap

Further details can be given in the following FTX-segment, if required.

DRAFT VERSION

FTX (C9) FREE TEXT (grp3)

+

e4451 Text Subject Qualifier: Allowed qualifiers:
 (M an..3) "AAA" = Description of Goods
 "AAI" = General information
 "CLR" = Container Loading Remarks
 "HAN" = Handling Instructions
 "SIN" = Special instructions
 "TEM" = Temporary stowage
 "ZZZ" = Mutually defined use

+

+

+

c108.e4440 Free Text: Description/Instructions/Remarks in plain
 (M an..70) language or coded, for specific cargo/equipment. Codes, etc. to be
 agreed between partners. One element with maximum field length 20
 characters, unless agreed otherwise.

,

N.B. This segment is not generally machine processable. Use of this segment must be agreed between partners!

This segment can be used for the following:

"AAA":Description of goods, plain language or codes, as agreed between partners. Maximum 20 characters.

"SIN":Additional information or instructions regarding special cargoes, equipment or breakbulk shipments.

"HAN":For handling instructions the following codes are recommended:

"AB" Away from boiler (eng.room)
 "OD" Ondeck stowage
 "TS" Top stowage
 "UD" Under deck
 "UT" Under deck top
 "UW" Under waterline
 "OT" On decktop
 "EO" Except on decktop
 "OP" On deck protected
 "KC" Keep cool
 "AL" Away from living quarters
 "BC" Block stowage
 "AF" Away from foodstuffs
 "NO" Not overstow

"CLR":Container loading remarks: the following codes are recommended:

"BD" Bundled
 "DM" Damaged mt
 "SW" Sweeper
 "ER" Escort required
 "DR" Dry reefer
 "HT" Hangertainer
 "DO" Doors open
 "MB" Mailbox

DRAFT VERSION

MEA (M9) MEASUREMENTS (grp3)

+

e6311 Measurement Application Qualifier: Allowed qualifiers:
 (M an..3) "WT" Grossweight
 "TAR" Tare weight

+

+

c174.e6411 Measure Unit Qualifier: Allowed qualifiers:
 (M an..3) "KGM" = kilogram = preferred
 "LBR" = pounds

:

c174.e6314 Measurement Value: The grossweight (= actual tareweight
 (D n..18) of the equipment plus its contents) in kilograms or pounds, as

qual

:

c174.e6162 Range Minimum: The minimum grossweight of range of
 (D n..18) shipments to be loaded/discharged in kilograms or pounds, as

qual

:

c174.e6152 Range Maximum: The The maximum grossweight of range of
 (D n..18) shipment to be loaded/discharged in kilograms or pounds, as qualified
 (no decimals).

,

Remarks:

In case ranges are given (date-elements c174.e6162 end c174.6152) data-element
 c174.e6314 is left out.

In case of an average weight, the values in minimum (c174.e6162) and maximum
 (c174.e6152) are the same.

DRAFT VERSION

DIM (C9) DIMENSIONS (grp3)

+

e6145 Dimension Qualifier: Allowed qualifiers are:
(M an..3) "1" = Gross dimensions (breakbulk)
"5" = Off-standard dims. (overlength front)
"6" = Off-standard dims. (overlength back)
"7" = Off-standard dims. (overwidth right)
"8" = Off-standard dims. (overwidth left)
"9" = Off-standard dims. (overheight)
"10" = External equipment dimensions (Non-ISO equipment)
Basically allowed qualifier "1" for breakbulk cargo and from "5" to "9" for odd-sized-cargo. However allowed from "5" to "9" for breakbulk cargo as additional information, if required.

+

c211.e6411 Measure Unit Qualifier: Allowed qualifiers:
(M an..3) "CMT" = Centimeters = preferred
"INH" = Inches

:

c211.e6168 Length Dimension. Breakbulk length or overlength for
(D n..15) containers, as qualified.

:

c211.e6140 Width Dimension: Breakbulk width or overwidth for
(D n..15) containers, as qualified.

:

c211.e6008 Height Dimension: Breakbulk height or overheight for
(D n..15) containers, as qualified.

,

N.B. This segment is only to be transmitted in case breakbulk, odd-sized-cargo and off-standard or non-ISO equipment is involved. In order to identify all relevant information, this segment may be repeated conditionally upto 9 times. The codes 5-9 for odd-sized cargo only, carrying just the overdimensions. In case exact dimensions are not known at time of sending the message, the composite data-elements c211.e6168, c211.e6140 and c211.e6008 to be filled with the value 0 (zero).

DRAFT VERSION

TMP (C1) TEMPERATURE (grp3)

+

e6245 Temperature qualifier: Allowed qualifiers:
 (M AN..3) "2" = Transport Temperature

+

c239.e6246 Temperature Setting: Actual temperature according to
 (R n3) Reefer List (no deviation allowed) at which the cargo is to be tran

:

c239.e6411 Measure Unit Qualifier: Allowed qualifiers:
 (R an..3) "CEL" = degrees Celsius = Preferred.
 "FAH" = degrees Fahrenheit

,

Remarks:

In case temperatures are not known at the time of sending the message, special handling of cooling/heating is indicated by mentioning the temperature qualifier only and leaving out the composite c239.

In spite of the field length of element c239.e6246 (temperature) is only N3, decimal mark and figure as well as negative values preceded by a sign (-) can be transmitted. Generally numeric data element values shall be regarded as positive unless they are preceded by a minus sign. The decimal mark and minus sign shall, however, not be counted as a character of the value when computing the maximum field length of a data element. Nevertheless, allowance has to be made for the character in transmission and reception.

Tenth of degrees have to be separated by a decimal point from full degrees (e.g. 18.5

For further explanation please refer to ISO 9735 "EDIFACT Application Level Syntax Rules", point 10 "Representation of numeric data element values".

DRAFT VERSION

RNG (C1) RANGE DETAILS (grp2)

+

e6167 Range Type Qualifier: Allowed qualifier:
(M an..3) "4" = Quantity range.

+

c280.e6411 Measure Unit Qualifier: Allowed qualifiers:
(M an..3) "CEL" = degrees Celsius
"FAH" = degrees Fahrenheit

:

c280.e6162 Range Minimum: Minimum temperature according to Reefer
(R n..18) List at which the cargo is to be transported.

:

c280.e6152 Range Maximum: Maximum temperature according to Reefer
(R n..18) List at which the cargo is to be transported.

,

Remarks:

Range minimum and maximum is only to be filled with different values in case it is allowed by the shipping line in charge of subject shipment, respectively the customer owing the goods. Otherwise c280.e6162 and c280.e6152 have to carry the same value. No deviation allowed.

DRAFT VERSION

LOC (M9) PLACE/LOCATION IDENTIFICATION (grp3)

+

e3227 Place/Location Qualifier: Allowed qualifiers:
 (M an..3) "9" = Port of Loading
 "11" = Port of discharge
 "13" = Transshipment port
 "64" = 1st optional port of discharge
 "68" = 2nd optional port of discharge
 "70" = 3rd optional port of discharge
 "80" = Original port of loading
 "83" = Place of delivery (to be used as final destination)
 "97" = Optional port of discharge.
 "152" = Next port of discharge

+

c517.e3225 Place/Location Identification: Namecode of the place/port, as
 (R an..25) qualified. Allowed codelists: UN-Locode or US-Census codes.
 Example codes: JPTYO = Tokyo
 USLAX = Los Angeles
 USOAK = Oakland
 USSEA = Seattle
 USCHI = Chicago
 For optional port of discharge (e3227 = "97"): "XXOPT".

:

c517.e1131 Code list qualifier. Allowed qualifiers:
 (O an..3) 139" = Port.

:

c517.e3055 Code list responsible agency, coded. Allowed codes:
 (O an..3) "112" = US, US Census Bureau, Schedule D for U S locations,
 Schedule K for foreign port locations.
 "6" = UN/ECE - United Nations - Economic Commission for Europe.
 (UN-Locodes).
 "ZZZ" = Optional ports.

+

c519.e3223 Related place/location one identification. The ISO
 (O an..25) country code.

:

c519.e1131 Code list qualifier. Allowed qualifier:
 (O an..3) "162" = Country.

:

c519.e3055 Code list responsible agency, coded. Allowed codes:
 (O an..3) "5" = ISO

+

c553.e3233 Related place/location two identification. The state or
 (O an..25) province code, postal abbreviations.

:

DRAFT VERSION

c553.e1131 Code list qualifier. Allowed qualifier:
(0 an..3) "163" = Country sub-entity; state or province.

,

Remarks:

1. If locodes other than UN-locodes are used the sender must verify with the recipient of the message if other than UN-locodes are acceptable/ processable. Composites c519 and c553 are only relevant if no UN-locodes are used.
2. Minimum 2 ports to be given: loading port and discharging port.
3. Use of qualifiers, other than those for port of loading and port of discharge, must be agreed between partners.

DRAFT VERSION

RFF (1) (M9) REFERENCE (grp3)

+

c506.e1153 Reference Qualifier: Allowed qualifiers:
(M an..3) "BM" = B/L-number, as dummy, in case non of the following codes are applicable.
"ET" = Excess Transportation Number to be used for leading Stowage position, in case of Breakbulk or odd-sized-cargo.
"BN" = Booking reference number.
"CN" = Carrier's reference number.
"CV" = Container operator's reference number.
"BST" = Block stow to be used in case the carrier wants to indicate that blocks of containers must be delivered via train or into barge.
"ZZZ" = Mutually agreed.

:

c506.e1154 Reference Number: For Qualifiers :
(R an..35) "BM" = always "1".
"ZZZ" = always "1".
"ET" =: Leading stowage location, containing relevant data for this consignment.
"BN" = Booking reference number assigned by carrier or agent.
"CN" = Carrier's reference number.
"CV" = Container operator's reference number.
"BST" = Mode of transport assigned by the carrier.
1 = Feeder
2 = Rail
8 = Barge

'

N.B. For breakbulk and odd-sized-cargo see chapter 3: Special User Guidelines.

Example: RFF+BM:1' or RFF+ET+0120106'

DRAFT VERSION

Group **grp4** (C9) EQD - EQA - NAD

EQD (M1) EQUIPMENT DETAILS (grp4)

+

e8053 Equipment Qualifier: Allowed qualifiers:
(M an..3) "CN" = Container

+

c237.e8260 Equipment Identification Number:
(D an..17)

1. The containernumber:

Format: One continuous string with the identification, prefix and number. Examples: SCXU 2387653 must be transmitted as "SCXU2387653", EU 876 must be transmitted as "EU876". The number will be treated as a character string. E.g. alphanumeric check-digits can be transmitted here. If this segment is used the unique equipment identification number must always be transmitted, although this element is not mandatory!

+

c224.e8155 Equipment Size and Type Identification: ISO size-type
(D an..4) code of 4 digits (ISO 6346).For unknown ISO size/type codes the following codes may be used:

"4****"	=	Length = 40ft, rest unknown
"2****"	=	Length = 20ft, rest unknown
"42***"	=	40ft 8'6", rest unknown
"22***"	=	20ft 8'6", rest unknown
"40***"	=	40ft 8'0", rest unknown
"20***"	=	20ft 8'0", rest unknown

For type indications see the next examples. (the length is always mandatory):

"2*0*" = 20ft Dry-box, rest unknown
"4*2*" = 40ft Reefer, rest unknown
etc. etc.

Other codes to be agreed between partners.

:
:
:

c224.e8154 Equipment Size and Type: To indicate the length of the
(D an..35) container in feet in relation to athwards bays and non ISO length containers (45' ; 48' ; 52').

+

+

DRAFT VERSION

e8249 Equipment status, coded.
(O an..3)

1:	Continental	11:	Direct delivery
2:	Export	12:	Bond transport
3:	Import	13:	Tranship to other vessel
4:	Remain on board	14:	Tranship to other pier
5:	Shifter	15:	Rail road transport
6:	Transhipment	16:	Road transport
7:	Hot delivery	17:	Barge transport
8:	MLB	18:	Temporary stowage
9:	MCB (Micro Land Bridge)	19:	Urgent unpacking
10:	Canada Bound transport	20:	Sea & Air

+

e8169 Full/Empty Indicator, coded. Allowed codes:
(D an..3)

"5"	=	Full
"4"	=	Empty.

,

DRAFT VERSION

EQA (C9) EQUIPMENT ATTACHED (grp4)

+

e8053 Equipment Qualifier: Allowed qualifiers:
(M an..3) "RG" = Reefer Generator
"CN" = Container
"CH" = Chassis

+

c237.e8260 Equipment Identification Number: The unitnumber.
(R an..17)

,

N.B. This segment may be used for transmission of attached equipment to container or for containers or other equipment stowed within one location with leading container in EQD (Platforms, Collapsable Flats, chassis, etc.).

DRAFT VERSION

NAD (C1) NAME AND ADDRESS (grp4)

+

e3035 Party Qualifier: Allowed code:
(M an..3) "CA" = Carrier of the cargo.
"CF" = Container operator

+

c082.e3039 Party Id Identification: Namecode of party to be billed for the
(M an..17) operation of subject equipment/cargo, if other than container operator.
This might be necessary to identify, in case operation, e.g. restow,
is caused due to a requirement from a party, which is not the contain-
er operator, e.g. another line, sharing ships space or the Terminal
operator.

:
:

c082.e1131 Code List Qualifier: Qualifier "172".
(R an..3)

:

c082.e3055 Code List Responsible Agency, coded. Allowed codes:
(R an..3) "20" = BIC (Bureau International des Containeurs)
"166" = US National Motor Freight Classification Association (SCAC)
"ZZZ" = Mutually defined.

,

DRAFT VERSION

Group **grp5** (C999) DGS - FTX

DGS (M1) DANGEROUS GOODS (grp5)

+

e8273 Dangerous Goods Regulations: Code "IMD" (IMO IMDG Code)
(R an..3)

+

c205.e8351 Hazard Code Identification: IMDG Code, e.g. "1.2" or "8".
(M an..7)

:

c205.e8078 Hazard Substance/item/page number: The IMDG code page number (English
(O an..7) version).

+

c234.e7124 UNDG Number: UN number of respective dangerous cargo transported
(O n4) (4 digits).

+

c223.e7106 Shipment Flashpoint: the actual flashpoint in degrees Celsius or
(O n3) Fahrenheit. For inserting temperatures below zero or tenth degrees please
refer to remarks under TMP-segment respectively to ISO 9735. If
different dangerous goods with different flashpoints within one load
to be transported, only the lowest flashpoint should be inserted.

:

c223.e6411 Measure Unit Qualifier: Allowed qualifiers:
(O an..3) "CEL" = degrees Celsius = Preferred
"FAH" = degrees Fahrenheit

+

e8339 Packing group, coded: The packing group code of the hazardous goods.
(O an..3)

+

e8364 EMS number: Emergency schedule number.
(O an..6)

+

e8410 MFAG: Medical First Aid Guide number.
(O an..4)

+

+

c235.e8158 Hazard Identification number, upper part.
(O an..4)

:

c235.e8186 Substance Identification number, lower part.
(O an4)

+

DRAFT VERSION

c236.e8246 Dangerous Goods Label Marking (1).
(O an..4) See below for possible use of this data element.

:

c236.e8246 Dangerous Goods Label Marking (2).
(O an..4)

:

c236.e8246 Dangerous Goods Label Marking (3).
(O an..4)

,

N.B. Use of this segment must be agreed between partners.

Possible use of data elements c.236.e8246 (1, 2 and 3):
IMDG Code list of dangerous goods sub label:

Subsidiary risk	sub label	code
Explosive	Explosive	1
Gas	Flammable gas	2.1
Gas	Non-flammable compressed gas	2.2
Gas	Poison gas	2.3
Flammable liquid	Flammable liquid F.P.<-18C	3.1
Flammable liquid	Flammable liquid F.P-18C till 23C	3.2
Flammable liquid	Flammable liquid F.P.23C upto/incl 61C	3.3
Flammable solid	Flammable solid	4.1
Flammable solid	Spontaneously combustible	4.2
Flammable solid	Dangerous when wet	4.3
Oxidizing agent	Oxidizing agent	5.1
Oxidizing agent	Oxidizing peroxide	5.2
Poison	Poison	6.1
Poison	Harmful	6.1 HFL
Poison	Infectious substance	6.2
Radio active	Radio active - cat 1	7
Radio active	Radio active - cat 2	7
Radio active	Radio active - cat 3	7
Corrosive	Corrosive	8
Misellaneous	Misellaneous	9

DRAFT VERSION

FTX (C1) FREE TEXT (grp5)

+

e4451 Text Subject Qualifier. Allowed qualifiers:
(M an..3) "AAC" = Dangerous goods additional information
"AAD" = Dangerous goods, technical name, proper shipping name.

+

+

+

c108.e4440 Free text: Description of hazard material in plain language.
(M an..70) One element of maximum 70 characters to be given only for the
(1) description. Transmit the text "NIL", if no description is available
and one or both of the following data elements must be transmitted.

:

c108.e4440 Free text: The net weight in kilos of the hazardous material to be
(O an..70) transmitted here.
(2)

:

c108.e4440 Free text: The DG-reference number as allocated by the central
(O an..70) planner, if known.
(3)

'

N.B. Use of this segment must be agreed between partners.

DRAFT VERSION

UNT (M1) MESSAGE TRAILER

+

e0074 Number of segments in the message, including UNH and UNT segments,
(M n..6) but excluding UNA, UNB and UNZ segments.

+

e0062 Message reference number: This reference must be identical to the
(M an..14) reference in the UNH-segment (e0062).

'

DRAFT VERSION

UNZ (M1) INTERCHANGE TRAILER

+

e0036 Interchange Control Count: The number of messages in the interchange.
(M n..6)

+

e0020 Interchange Control Reference: This reference must be identical to
(M an..14) the reference in the UNB-segment (e0020).

,

DRAFT VERSION

5. SPECIAL USER GUIDELINES

To follow.

DRAFT VERSION

6. EXAMPLE MESSAGE

The segments of the example message are all shown on separate lines. In accordance with the Edifact Syntax Rules, however, no Carriage Returns (CR) and/or Line Feeds (LF) must be transmitted.

Example follows.

DRAFT VERSION

This page is reserved for the example message

DRAFT VERSION

8. MESSAGE STRUCTURE DIAGRAM

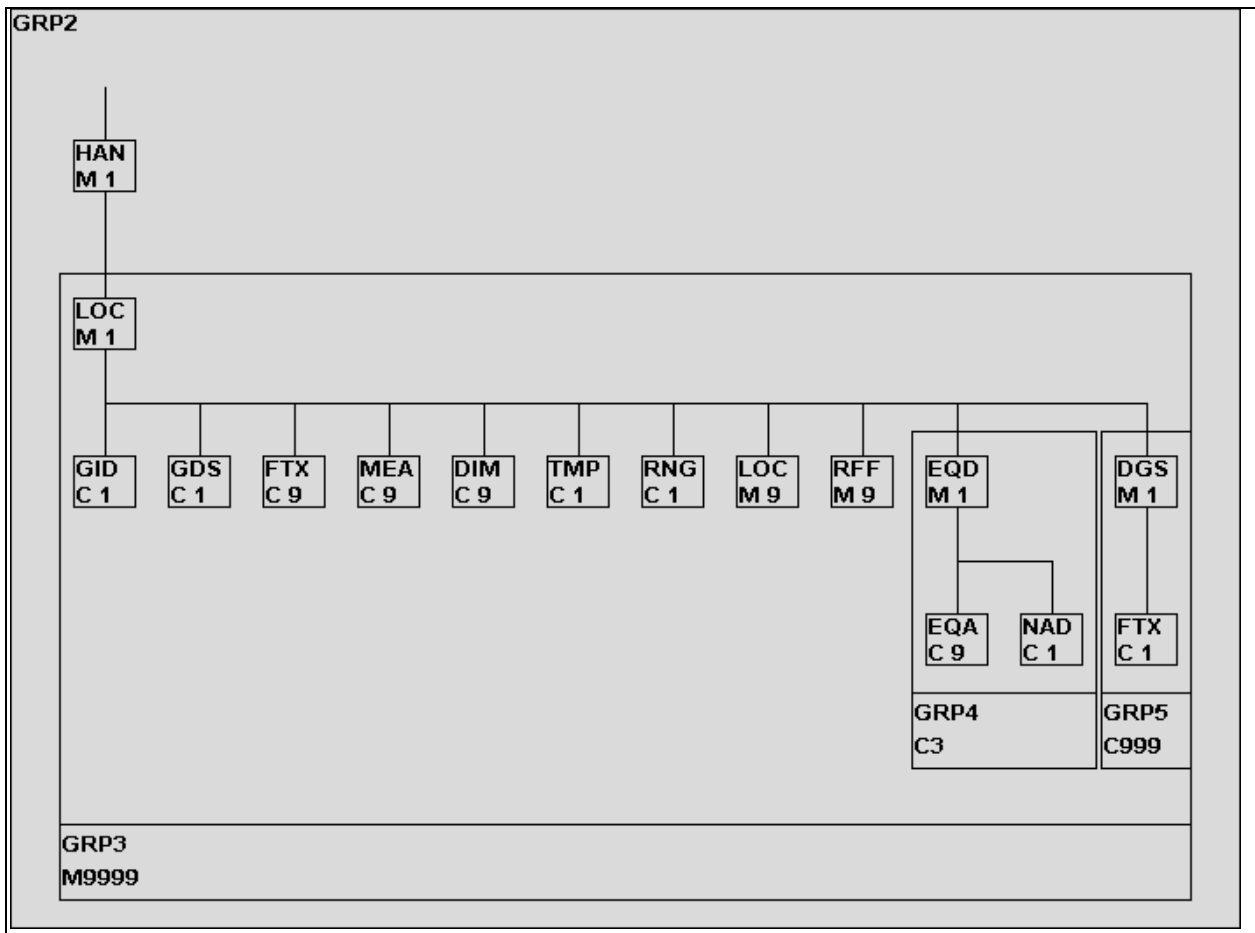
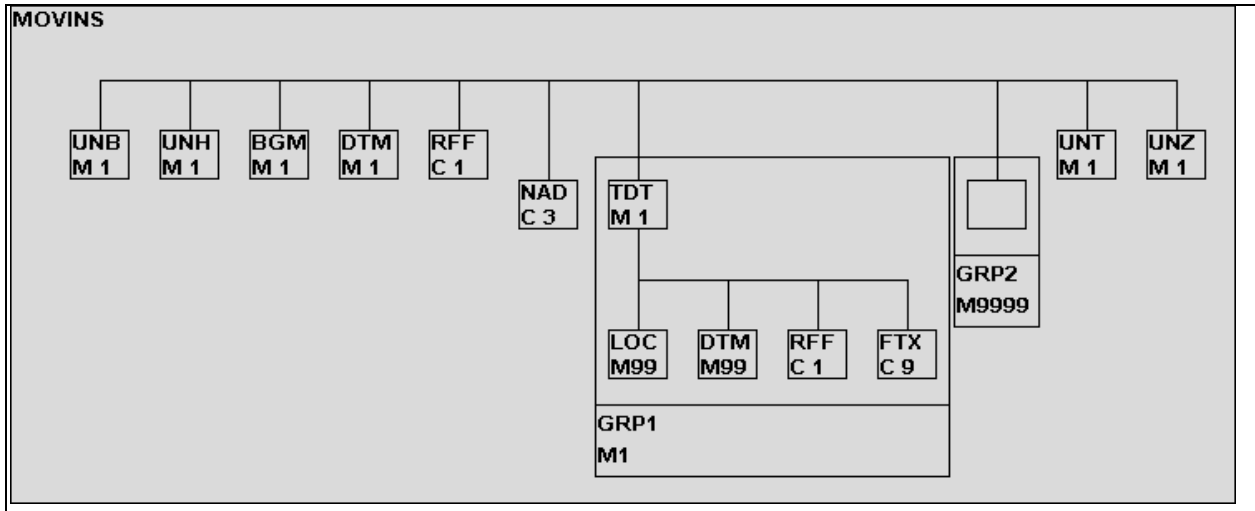

DRAFT VERSION

This page is left blank intentionally

DRAFT VERSION

9. SEGMENT DIRECTORY (D.95B)**BGM BEGINNING OF MESSAGE**

To indicate the type and function of a message and to transmit the identifying number.

C002	DOCUMENT/MESSAGE NAME	C	
1001	DOCUMENT/MESSAGE NAME, CODED	C	AN..3
1131	CODE LIST QUALIFIER	C	AN..3
3055	CODE LIST RESPONSIBLE AGENCY, CODED	C	AN..3
1000	DOCUMENT/MESSAGE NAME	C	AN..35
1004	DOCUMENT/MESSAGE NUMBER	C	AN..35
1225	MESSAGE FUNCTION, CODED	C	AN..3
4343	RESPONSE TYPE, CODED	C	AN..3

DGS DANGEROUS GOODS

To identify dangerous goods.

8273	DANGEROUS GOODS REGULATIONS, CODED	C	AN..3
C205	HAZARD CODE	C	
8351	HAZARD CODE IDENTIFICATION	M	AN..7
8078	HAZARD SUBSTANCE/ITEM/PAGE NUMBER	C	AN..7
8092	HAZARD CODE VERSION NUMBER	C	AN..10
C234	UNDG INFORMATION	C	
7124	UNDG NUMBER	C	N4
7088	DANGEROUS GOODS FLASHPOINT	C	AN..8
C223	DANGEROUS GOODS SHIPMENT FLASHPOINT	C	
7106	SHIPMENT FLASHPOINT	C	N3
6411	MEASURE UNIT QUALIFIER	C	AN..3
8339	PACKING GROUP, CODED	C	AN..3
8364	EMS NUMBER	C	AN..6
8410	MFAG	C	AN..4
8126	TREM CARD NUMBER	C	AN..10
C235	HAZARD IDENTIFICATION	C	
8158	HAZARD IDENTIFICATION NUMBER, UPPER PART	C	AN..4
8186	SUBSTANCE IDENTIFICATION NUMBER, LOWER PART	C	AN4
C236	DANGEROUS GOODS LABEL	C	
8246	DANGEROUS GOODS LABEL MARKING	C	AN..4
8246	DANGEROUS GOODS LABEL MARKING	C	AN..4
8246	DANGEROUS GOODS LABEL MARKING	C	AN..4
8255	PACKING INSTRUCTION, CODED	C	AN..3
8325	CATEGORY OF MEANS OF TRANSPORT, CODED	C	AN..3
8211	PERMISSION FOR TRANSPORT, CODED	C	AN..3

DRAFT VERSION

DIM DIMENSIONS

To specify dimensions.

6145	DIMENSION QUALIFIER	M	AN..3
C211	DIMENSIONS	M	
6411	MEASURE UNIT QUALIFIER	M	AN..3
6168	LENGTH DIMENSION	C	N..15
6140	WIDTH DIMENSION	C	N..15
6008	HEIGHT DIMENSION	C	N..15

DTM DATE/TIME/PERIOD

To specify date, time, period.

C507	DATE/TIME/PERIOD	M	
2005	DATE/TIME/PERIOD QUALIFIER	M	AN..3
2380	DATE/TIME/PERIOD	C	AN..35
2379	DATE/TIME/PERIOD FORMAT QUALIFIER	C	AN..3

EQA ATTACHED EQUIPMENT

To specify attached or related equipment.

8053	EQUIPMENT QUALIFIER	M	AN..3
C237	EQUIPMENT IDENTIFICATION	C	
8260	EQUIPMENT IDENTIFICATION NUMBER	C	AN..17
1131	CODE LIST QUALIFIER	C	AN..3
3055	CODE LIST RESPONSIBLE AGENCY, CODED	C	AN..3
3207	COUNTRY, CODED	C	AN..3

EQD EQUIPMENT DETAILS

To identify a unit of equipment.

8053	EQUIPMENT QUALIFIER	M	AN..3
C237	EQUIPMENT IDENTIFICATION	C	
8260	EQUIPMENT IDENTIFICATION NUMBER	C	AN..17
1131	CODE LIST QUALIFIER	C	AN..3
3055	CODE LIST RESPONSIBLE AGENCY, CODED	C	AN..3
3207	COUNTRY, CODED	C	AN..3
C224	EQUIPMENT SIZE AND TYPE	C	
8155	EQUIPMENT SIZE AND TYPE IDENTIFICATION	C	AN..10
1131	CODE LIST QUALIFIER	C	AN..3
3055	CODE LIST RESPONSIBLE AGENCY, CODED	C	AN..3
8154	EQUIPMENT SIZE AND TYPE	C	AN..35
8077	SHIPPER SUPPLIED EQUIPMENT INDICATOR, CODED	C	AN..3
8249	EQUIPMENT STATUS, CODED	C	AN..3
8169	FULL/EMPTY INDICATOR, CODED	C	AN..3

DRAFT VERSION

FTX FREE TEXT

To provide free form or coded text information.

4451	TEXT SUBJECT QUALIFIER	M	AN..3
4453	TEXT FUNCTION, CODED	C	AN..3
C107	TEXT REFERENCE	C	
4441	FREE TEXT, CODED	M	AN..3
1131	CODE LIST QUALIFIER	C	AN..3
3055	CODE LIST RESPONSIBLE AGENCY, CODED	C	AN..3
C108	TEXT LITERAL	C	
4440	FREE TEXT	M	AN..70
4440	FREE TEXT	C	AN..70
4440	FREE TEXT	C	AN..70
4440	FREE TEXT	C	AN..70
4440	FREE TEXT	C	AN..70
3453	LANGUAGE, CODED	C	AN..3

GDS NATURE OF CARGO

To indicate the type of cargo as a general classification.

C703	NATURE OF CARGO	C	
7085	NATURE OF CARGO, CODED	M	AN..3
1131	CODE LIST QUALIFIER	C	AN..3
3055	CODE LIST RESPONSIBLE AGENCY, CODED	C	AN..3

DRAFT VERSION

GID GOODS ITEM DETAILS

To indicate totals of a goods item.

1496	GOODS ITEM NUMBER	C	N..5
C213	NUMBER AND TYPE OF PACKAGES	C	
7224	NUMBER OF PACKAGES	M	N..8
7065	TYPE OF PACKAGES IDENTIFICATION	C	AN..17
1131	CODE LIST QUALIFIER	C	AN..3
3055	CODE LIST RESPONSIBLE AGENCY, CODED	C	AN..3
7064	TYPE OF PACKAGES	C	AN..35
C213	NUMBER AND TYPE OF PACKAGES	C	
7224	NUMBER OF PACKAGES	M	N..8
7065	TYPE OF PACKAGES IDENTIFICATION	C	AN..17
1131	CODE LIST QUALIFIER	C	AN..3
3055	CODE LIST RESPONSIBLE AGENCY, CODED	C	AN..3
7064	TYPE OF PACKAGES	C	AN..35
C213	NUMBER AND TYPE OF PACKAGES	C	
7224	NUMBER OF PACKAGES	M	N..8
7065	TYPE OF PACKAGES IDENTIFICATION	C	AN..17
1131	CODE LIST QUALIFIER	C	AN..3
3055	CODE LIST RESPONSIBLE AGENCY, CODED	C	AN..3
7064	TYPE OF PACKAGES	C	AN..35

HAN HANDLING INSTRUCTIONS

To specify handling and where necessary, notify hazards.

C524	HANDLING INSTRUCTION	C	
4079	HANDLING INSTRUCTIONS, CODED	C	AN..3
1131	CODE LIST QUALIFIER	C	AN..3
3055	CODE LIST RESPONSIBLE AGENCY, CODED	C	AN..3
4078	HANDLING INSTRUCTIONS	C	AN..70
C218	HAZARDOUS MATERIAL	C	
7419	HAZARDOUS MATERIAL CLASS CODE, IDENTIFICATION	C	AN..4
1131	CODE LIST QUALIFIER	C	AN..3
3055	CODE LIST RESPONSIBLE AGENCY, CODED	C	AN..3

DRAFT VERSION

LOC PLACE/LOCATION IDENTIFICATION

To identify a country/place/location/related location one related location two.

3227	PLACE/LOCATION QUALIFIER	M	AN..3
C517	LOCATION IDENTIFICATION	C	
3225	PLACE/LOCATION IDENTIFICATION	C	AN..25
1131	CODE LIST QUALIFIER	C	AN..3
3055	CODE LIST RESPONSIBLE AGENCY, CODED	C	AN..3
3224	PLACE/LOCATION	C	AN..17
C519	RELATED LOCATION ONE IDENTIFICATION	C	
3223	RELATED PLACE/LOCATION ONE IDENTIFICATION	C	AN..25
1131	CODE LIST QUALIFIER	C	AN..3
3055	CODE LIST RESPONSIBLE AGENCY, CODED	C	AN..3
3222	RELATED PLACE/LOCATION ONE	C	AN..70
C553	RELATED LOCATION TWO IDENTIFICATION	C	
3233	RELATED PLACE/LOCATION TWO IDENTIFICATION	C	AN..25
1131	CODE LIST QUALIFIER	C	AN..3
3055	CODE LIST RESPONSIBLE AGENCY, CODED	C	AN..3
3232	RELATED PLACE/LOCATION TWO	C	AN..70
5479	RELATION, CODED	C	AN..3

MEA MEASUREMENTS

To specify physical measurements, including dimension tolerances, weights and counts.

6311	MEASUREMENT APPLICATION QUALIFIER	M	AN..3
C502	MEASUREMENT DETAILS	C	
6313	MEASUREMENT DIMENSION, CODED	C	AN..3
6321	MEASUREMENT SIGNIFICANCE, CODED	C	AN..3
6155	MEASUREMENT ATTRIBUTE, CODED	C	AN..3
6154	MEASUREMENT ATTRIBUTE	C	AN..70
C174	VALUE/RANGE	C	
6411	MEASURE UNIT QUALIFIER	M	AN..3
6314	MEASUREMENT VALUE	C	N..18
6162	RANGE MINIMUM	C	N..18
6152	RANGE MAXIMUM	C	N..18
6432	SIGNIFICANT DIGITS	C	N..2
7383	SURFACE/LAYER INDICATOR, CODED	C	AN..3

DRAFT VERSION

NAD NAME AND ADDRESS

To specify the name/address and their related function, either by C082 only and/or unstructured by C058 or structured by C080 thru 3207.

3035	PARTY QUALIFIER	M	AN..3
C082	PARTY IDENTIFICATION DETAILS	C	
3039	PARTY ID IDENTIFICATION	M	AN..35
1131	CODE LIST QUALIFIER	C	AN..3
3055	CODE LIST RESPONSIBLE AGENCY, CODED	C	AN..3
C058	NAME & ADDRESS	C	
3124	NAME AND ADDRESS LINE	M	AN..35
3124	NAME AND ADDRESS LINE	C	AN..35
3124	NAME AND ADDRESS LINE	C	AN..35
3124	NAME AND ADDRESS LINE	C	AN..35
3124	NAME AND ADDRESS LINE	C	AN..35
C080	PARTY NAME	C	
3036	PARTY NAME	M	AN..35
3036	PARTY NAME	C	AN..35
3036	PARTY NAME	C	AN..35
3036	PARTY NAME	C	AN..35
3036	PARTY NAME	C	AN..35
3045	PARTY NAME FORMAT, CODED	C	AN..3
C059	STREET	C	
3042	STREET AND NUMBER/P.O.BOX	M	AN..35
3042	STREET AND NUMBER/P.O.BOX	C	AN..35
3042	STREET AND NUMBER/P.O.BOX	C	AN..35
3164	CITY NAME	C	AN..35
3229	COUNTRY SUB-ENTITY IDENTIFICATION	C	AN..9
3251	POSTCODE IDENTIFICATION	C	AN..9
3207	COUNTRY, CODED	C	AN..3

DRAFT VERSION

RFF REFERENCE

To specify a reference.

C506	REFERENCE	M	
1153	REFERENCE QUALIFIER	M	AN..3
1154	REFERENCE NUMBER	C	AN..35
1156	LINE NUMBER	C	AN..6
4000	REFERENCE VERSION NUMBER	C	AN..35

RNG RANGE DETAILS

To identify a range.

6167	RANGE TYPE QUALIFIER	M	AN..3
C280	RANGE	C	
6411	MEASURE UNIT QUALIFIER	M	AN..3
6162	RANGE MINIMUM	C	N..18
6152	RANGE MAXIMUM	C	N..18

DRAFT VERSION

TDT DETAILS OF TRANSPORT

To specify mode and means of transport.

8051	TRANSPORT STAGE QUALIFIER	M	AN..3
8028	CONVEYANCE REFERENCE NUMBER	C	AN..17
C220	MODE OF TRANSPORT	C	
8067	MODE OF TRANSPORT, CODED	C	AN..3
8066	MODE OF TRANSPORT	C	AN..17
C228	TRANSPORT MEANS	C	
8179	TYPE OF MEANS OF TRANSPORT IDENTIFICATION	C	AN..8
8178	TYPE OF MEANS OF TRANSPORT	C	AN..17
C040	CARRIER	C	
3127	CARRIER IDENTIFICATION	C	AN..17
1131	CODE LIST QUALIFIER	C	AN..3
3055	CODE LIST RESPONSIBLE AGENCY, CODED	C	AN..3
3128	CARRIER NAME	C	AN..35
8101	TRANSIT DIRECTION, CODED	C	AN..3
C401	EXCESS TRANSPORTATION INFORMATION	C	
8457	EXCESS TRANSPORTATION REASON, CODED	M	AN..3
8459	EXCESS TRANSPORTATION RESPONSIBILITY, CODED	M	AN..3
7130	CUSTOMER AUTHORIZATION NUMBER	C	AN..17
C222	TRANSPORT IDENTIFICATION	C	
8213	ID OF MEANS OF TRANSPORT IDENTIFICATION	C	AN..9
1131	CODE LIST QUALIFIER	C	AN..3
3055	CODE LIST RESPONSIBLE AGENCY, CODED	C	AN..3
8212	ID OF MEANS OF TRANSPORT	C	AN..35
8453	NATIONALITY OF MEANS OF TRANSPORT, CODED	C	AN..3
8281	TRANSPORT OWNERSHIP, CODED	C	AN..3

TMP TEMPERATURE

To specify the temperature range and/or setting.

6245	TEMPERATURE QUALIFIER	M	AN..3
C239	TEMPERATURE SETTING	C	
6246	TEMPERATURE SETTING	C	N3
6411	MEASURE UNIT QUALIFIER	C	AN..3

DRAFT VERSION

UNB INTERCHANGE HEADER

To start, identify and specify an interchange.

S001	SYNTAX IDENTIFIER	M	
0001	SYNTAX IDENTIFIER	M	A4
0002	SYNTAX VERSION NUMBER	M	N1
S002	INTERCHANGE SENDER	M	
0004	SENDER IDENTIFICATION	M	AN..35
0007	PARTNER IDENTIFICATION CODE QUALIFIER	C	AN..4
0008	ADDRESS FOR REVERSE ROUTING	C	AN..14
S003	INTERCHANGE RECIPIENT	M	
0010	RECIPIENT IDENTIFICATION	M	AN..35
0007	PARTNER IDENTIFICATION CODE QUALIFIER	C	AN..4
0014	ROUTING ADDRESS	C	AN..14
S004	DATE/TIME OF PREPARATION	M	
0017	DATE OF PREPARATION	M	N6
0019	TIME OF PREPARATION	M	N4
0020	INTERCHANGE CONTROL REFERENCE	M	AN..14
S005	RECIPIENTS REFERENCE PASSWORD	C	
0022	RECIPIENT'S REFERENCE/PASSWORD	M	AN..14
0025	RECIPIENT'S REFERENCE/PASSWORD QUALIFIER	C	AN2
0026	APPLICATION REFERENCE	C	AN..14
0029	PROCESSING PRIORITY CODE	C	A1
0031	ACKNOWLEDGEMENT REQUEST	C	N1
0032	COMMUNICATIONS AGREEMENT ID	C	AN..35
0035	TEST INDICATOR	C	N1

DRAFT VERSION

UNH MESSAGE HEADER

To head, identify and specify a message.

0062	MESSAGE REFERENCE NUMBER	M	AN..14
S009	MESSAGE IDENTIFIER	M	
0065	MESSAGE TYPE IDENTIFIER	M	AN..6
0052	MESSAGE TYPE VERSION NUMBER	M	AN..3
0054	MESSAGE TYPE RELEASE NUMBER	M	AN..3
0051	CONTROLLING AGENCY	M	AN..2
0057	ASSOCIATION ASSIGNED CODE	C	AN..6
0068	COMMON ACCESS REFERENCE	C	AN..35
S010	STATUS OF THE TRANSFER	C	
0070	SEQUENCE MESSAGE TRANSFER NUMBER	M	N..2
0073	FIRST/LAST SEQUENCE MESSAGE TRANSFER INDICATION	C	A1

UNT MESSAGE TRAILER

To end and check the completeness of a message.

0074	NUMBER OF SEGMENTS IN A MESSAGE	M	N..6
0062	MESSAGE REFERENCE NUMBER	M	AN..14

UNZ INTERCHANGE TRAILER

To end and check the completeness of an interchange.

0036	INTERCHANGE CONTROL COUNT	M	N..6
0020	INTERCHANGE CONTROL REFERENCE	M	AN..14