

DRAFT

USER MANUAL
(IMPLEMENTATION GUIDE)

UN/EDIFACT STOWAGE MESSAGE

MOVINS

Version 2.0.4

D.95B

Version :	2.0.4
Date :	September 1995
Source :	Joint MOVINS 2.0 Development Team (JMDT) SMDG User Group for Shipping Lines and Container Terminals Asia Edifact Board Transport Working Group (AS TWG) Tradegate Maritime Strategy Group (TMSG)

© JMDT

Information in this document is subject to change without notice.

The "Joint MOVINS 2.0 Development Team" (JMDT) claims full copyright to this manual and its contents. The manual may be copied and used by anyone, without the consent of the JMDT.

It is not allowed to change the contents of this manual!

CONTENTS

0.	INTRODUCTION	iii
1.	ADDRESSES	iv
2.	GENERAL	v
3.	VERSIONS	vii
4.	DESCRIPTION	1
5.	SPECIAL USER GUIDELINES	36
6.	EXAMPLES	37
7.	EXAMPLE MESSAGE	50
8.	MESSAGE STRUCTURE DIAGRAM	52
9.	SEGMENT DIRECTORY (D.95B)	54
10.	SMDG EDI-ELECTRONIC DATA INTERCHANGE UNDERSTANDING	64

This page is left blank intentionally

0. INTRODUCTION

The instructions are valid for the "UN/EDIFACT UNITED NATIONS STANDARD MESSAGE (UNSM) DRAFT STOWAGE INSTRUCTION MESSAGE" (mnemonic MOVINS), as designed by the SMDG (User Group for Shipping Lines and Container Terminals).

The instructions in this manual are valid for Full Container Vessels, Container Feeder Vessels and Roll on/Roll off (Ro/Ro) Vessels.

This manual is intended for use in the stowage planning within the transport industry like: ship operators, tonnage centers, terminal operators, etc.

This "User Manual" (or "Implementation Guide") version 2.0 was developed in 1994 by the "Joint MOVINS 2.0 Development Team (JMDT)", consisting of the active members of the **User Group for Shipping Lines and Container Terminals SMDG**, the **Asia Edifact Board Transport Working Group** and the **Tradegate Maritime Strategy Group (Australia)**.

The **SMDG** is a "Pan European User Group" under the auspices of the **Western European Edifact Board (WEEB)**.

1. ADDRESSES

Any remarks, comments or questions can be addressed to one of the following addresses:

SMDG Secretariat

c/o ECT

P.O.Box 7400

3000 HK Rotterdam

The Netherlands

Phone: 31-10-4916308

Fax: 31-10-4916069

For:

- Europe

- Africa

- Middle East

- North, Middle, South America

Asia Edifact Board

Transport Working Group

c/o Japanese Shipowners' Association

Coordination Division

Kaiun Building, 2-6-4 Hirakawa-cho

Chiyoda-ku, Tokyo 102, Japan

Phone: 81-3-3264-7175

Fax: 81-3-3262-4761

For:

- Far Eastern Countries

Tradegate Maritime Strategy Group

c/o Tradegate Australia Ltd.

2nd Floor, 468 St Kilda Road,

MELBOURNE VIC 3004

Australia

Phone: 61-3-98668833

Fax: 61-3-98208940

For:

- Australia

or to any active member of the SMDG, AS TWG or TMSG.

2. GENERAL

The EDIFACT Stowage instruction "MOVINS" will be used to transmit information about ALL activities like discharging, shifting, restowing and loading on a specified means of transport from the operator or owner of the means of transport to any party involved with the operation on this means of transport at a certain place.

In general only complete messages "MOVINS" have to be transmitted. Alternatively it may be agreed between EDI-partners to transmit a partial "MOVINS" messages. So it is possible to send "MOVINS" for Discharge only, followed by Loading, Restow and Shift.

The Principle

The handling instructions given in the "MOVINS" message will apply to the information available in the planning system of the terminal. The details of the vessel, like number of bays and rows/tiers per bay under and on deck, should be known by the planning system of the terminal.

This message is to be transmitted in general from the operator/owner of a MoT or a stowage centre to e.g. the terminal operator. Generally, information transmitted in a "MOVINS" message applies to the data previously received in a "BAPLIE" message. The results of the operation optionally will be reflected in a new BAPLIE message.

The receiver of this message is able and may extract information from the message and incorporate respectively build up a new Bayplan message "BAPLIE" as the message structure of "MOVINS" is based on the "BAPLIE" message. The sequence of related segments such as DTM,RFF,NAD followed by segments TDT/LOC/DTM of group 1, is the same as in the "BAPLIE" message.

Conventions

In this document a data element will be identified by the lowercase letter "e" followed by its element number (example: e8053). A data element within a composite will be identified by the lowercase letter "c" followed by the composite number followed by a full stop "." followed by the lowercase letter "e" followed by the element number (example: c237.e8260).

Immediately below the segment tags and data element identification the usage of same will be mentioned as follows:

'M' = mandatory:	The segment or data element is mandatory and must be given.
'R' = required:	The segment or data element is conditional but MUST be used anyway.
'D' = dependent:	The segment or data element is conditional and its use depends on some condition. This condition must be clarified in the description.
'A' = recommended:	The segment or data element is conditional and its use is recommended.
'O' = optional:	The segment or data element is conditional and its use is optional at the discretion of the sender.
'X' = not used:	The segment must not be used.

Next to the usage indicator the official format of the field will be given, i.e. a4 or an..15. The description may further limit the format of the field, f.e. a field with a format an..17 may be limited to an12 by its description.

If composites or data-elements are repeated within a segment, respectively a composite, the occurrences of the composites or data-elements can be indicated by

its sequence number within the segment or composite between brackets, e.g. "(1)" being the first occurrence of the composite or data-element within the segment. If its occurrence within the segment or composite is of no relevance then the sequence number will not be mentioned. If the sequence numbers are mentioned, but not all of them (e.g. only 2 out of 5 occurrences are described), then the remaining occurrences may NOT be used, unless agreed otherwise between partners.

Data elements within the segments that are not mentioned here will not be used, resp. should not contain important information, since they will probably not be seen by the recipient, unless agreed otherwise.

SMDG recommends to use only data elements, qualifiers and codes described in this manual. If partners agree to use additional data elements, qualifiers and codes, not described in this manual, then specific and detailed agreement about those data elements, qualifiers and codes should be made!

Optional data elements may be omitted, unless specifically made compulsory by this manual (Indicator "R" = required), or unless agreed otherwise between partners.

In no case neither mandatory segments according to the Stowage Message Documentation "MOVINS" nor mandatory composites or data elements according to the relevant Segment Directory may be omitted.

3. VERSIONS

Data elements, composites and segments of the **UN/Edifact draft directory D.95B** are used in this manual.

Codes and qualifiers used, are according to **UN/EDIFACT Directory D.95B Code List**.

In some occasions, however, the required code or qualifier could not be found in the code list. In such cases a temporary code was assigned, awaiting the final code allocation from the UN/Edifact Board Code commission.

Also in some cases small amendments to the message structure were necessary. This manual anticipates on the approval of the respective CR (Change Request) or DMR (Data Maintenance Request) by the UN/Edifact Board. The structure of the message, as given in chapter 7, was agreed as such by the members of SMDG and will be implemented accordingly.

In version 2.0.4. of this manual all agreed and accepted amendments have been incorporated until the meeting of september 1995 in London/UK.

This page is left blank intentionally.

4. DESCRIPTION

UNB (M1) INTERCHANGE HEADER

+

s001.e0001 Syntax Identifier: Always "UNOA", indicating the use
(M a4) of level "A" character set.

:

s001.e0002 Syntax Version Number: Always "1".
(M a1)

+

s002.e0004 Sender Identification: Name code of the sender of the
(M an..35) interchange (message). To be agreed between partners.

+

s003.e0010 Recipient Identification: Name code of the recipient of
(M an..35) the interchange (message). To be agreed between partners.

+

s004.e0017 Date of preparation: Preparation date of the interchange
(M n6) (message).

:

s004.e0019 Time of preparation: Preparation time of the interchange
(M n4) (message).

+

e0020 Interchange control reference: A reference allocated by
(M an..14) the sender, uniquely identifying an interchange. This reference must
also be transmitted in the Interchange Trailer segment UNZ.

+

+

+

+

+

e0032 Communications Agreement Id: A code identifying the
(A an..35) shipping line of the vessel (BIC, SCAC or mutually agreed).
N.B. This code enables proper routing of the message by the
recipient.

,

UNH (M1) MESSAGE HEADER

+

e0062 Message reference number: A reference allocated by the sender,
(M an..14) uniquely identifying a message. This reference must also be
transmitted in the Message Trailer segment UNT.

+

s009.e0065 Message Type Identifier: The name of the UNSM or standard
(M an..6) EDIFACT message. In this case always "MOVINS".

:

s009.e0052 Message Type Version Number: The version number of the message.
(M an..3) See EDIFACT documentation. At this moment the version is "D".

:

s009.e0054 Message Type Release Number: The release number of the message.
(M an..3) See EDIFACT documentation. At this moment the release number is
"95B".

:

s009.e0051 Controlling Agency: The code of the controlling agency. For
(M an..2) this message the controlling agency is "UN".

:

s009.e0057 Association Assigned Code: The applicable SMDG User Manual version
(R an..6) number. For this manual always: "SMDG20". This will enable the
recipient of the message to translate the message correctly, even if
older versions are still in use.

,

BGM (M1) BEGINNING OF MESSAGE

+

+

e1004 Document/Message Number: Reference allocated by the sender individually, taken from the application.
(R an..35)

+

e1225 Message Function, Coded: Code indicating the function of the message. Acceptable codes are:
(R an..3)

"2"	= Add.	Add to previous message.
"3"	= Delete.	Delete from previous message.
"4"	= Change.	Message with changes on previous message.
"5"	= Replace.	Message replacing a previous one.
"9"	= Original.	First or basic message.
"22"	= Final.	The final message in a series of BAPLIE messages.

,

Remarks: In principle only original messages (code "9") are allowed. The other codes may be used after prior agreement between sender and recipient.

DTM (M1) DATE/TIME/PERIOD

+

c507.e2005 Date/Time/Period Qualifier: Code "137" (Document/Message
(M an..3) date/Time)

:

c507.e2380 Date/Time/Period: Date or date/time of compiling the message.
(R an..35)

:

c507.e2379 Date/Time/Period Format Qualifier: Allowed qualifiers:
(R an..3) "101" = YYMMDD
"201" = YYMMDDHHMM
"301" = YYMMDDHHMMZZZ ("ZZZ" = Timezone, e.g. "GMT" or other)

,

RFF (X) REFERENCE

This segment not to be used.

NAD (X) NAME AND ADDRESS

This segment is not to be used.

Group **grp1** (M1) TDT - LOC - DTM - RFF - FTX.

TDT (M1) DETAILS OF TRANSPORT (grp1)

+

e8051 Transport Stage Qualifier: Code "20" (Main Carriage)
(M an..3)

+

e8028 Conveyance Reference Number: Discharge voyage number as
(R an..17) assigned by the Operating Carrier or his agent. The trade route
could be included in this voyage number, if required.

+

+

+

c040.e3127 Carrier Identification: Carrier name, coded. Codes
(R an..17) to be agreed or standard carrier alpha code (SCAC).

:

c040.e1131 Code List Qualifier: Code "172" (Carrier Code)
(R an..3)

:

c040.e3055 Code list responsible agency, coded. Allowed codes:
(R an..3) "20" = BIC (Bureau International des Containeurs)
"166" = US National Motor Freight Classification Association
(SCAC)
"ZZZ" = Mutually agreed.

+

+

+

c222.e8213 Id of Means of Transport Identification. Vessel code:
(R an..9) 1. Callsign (recommended)
2. Lloyd's Code
3. Mutually agreed vessel code (eg. barges)

:

c222.e1131 Code List Qualifier: Allowed qualifiers:
(R an..3) "103" = Call Sign
"146" = Lloyd's Code
"ZZZ" = Mutually agreed

:

c222.e3055 Code list responsible agency, coded. Allowed code:
(R an..3) "11" = Lloyd's register of shipping. Only to be used when
Lloyd's COde is used for vessel/barge identification
(Code "146" in c222.e1131).
"ZZZ" = Mutually defined. To be used in all other cases.

:

c222.e8212 Id. of means of transport: Full name of the vessel, if requi-
(R an..17) red.

:

c222.e8453 Nationality of Means of Transport: Coded according to UN-coun-
(R an..3) trycode (ISO 3166).

,

LOC (M99) PLACE/LOCATION IDENTIFICATION (grp1)

+

e3227 Place/Location Qualifier: Allowed qualifiers:
 (M an..3) "5" = Place of Departure
 "61" = Next port of call
 "92" = This qualifier can occur 1 to n times and is given in
 sequence of the rotation.

+

c517.e3225 Place/Location Identification: Location code of the actual
 (R AN..17) place of departure (normally the sender of the message). If possible,
 UN-Locodes of 5 characters according to UN recommendation no.16.
 must be used.

:

c517.e1131 Code list qualifier. Allowed qualifiers
 (R an..3) "139" = Port.

:

c517.e3055 Code list responsible agency, coded. Allowed codes:
 (R an..3) "112" = US, US Census Bureau, Schedule D for U S location
 schedule K for foreign port locations.
 "6" = UN/ECE - United Nations - Economic Commission for
 Europe. (UN-Locodes).

+

c519.e3223 Related place/location one identification. The ISO
 (O an..25) country code.

:

c519.e1131 Code list qualifier. Allowed qualifier:
 (O an..3) "162" = Country.

:

c519.e3055 Code list responsible agency, coded. Allowed codes:
 (O an..3) "5" = ISO

+

c553.e3233 Related place/location two identification. The
 (O an..25) state or province code, postal abbreviations.

:

c553.e1131 Code list qualifier. Allowed qualifier:
 (O an..3) "163" = Country sub-entity; state or province.

,

N.B. If locodes other than UN-locodes are used the sender must verify with the
 recipient of the message if other than UN-locodes are acceptable/ processable.
 Composites c519 and c553 are only relevant if no UN-locodes are used.

DTM (M99) DATE/TIME/PERIOD (grp1)

+

c507.e2005 Date/Time/Period Qualifier: Allowed qualifiers:
(M an..3) "132" = estimated date or date/time of arrival at the port
for which handling instructions are ment.

:

c507.e2380 Date/Time/Period: Date or date/time in local time
(R an..35) when Means of Transport has arrived/departed or is expected to depart
at the senders port or is expected to arrive at the next port of
call.

:

c507.e2379 Date/Time/Period Format Qualifier. Allowed quali-
(R an..3) fiers:
"101" = YYMMDD
"201" = YYMMDDHHMM
"301" = YYMMDDHHMMZZZ ("ZZZ" = Timezone, e.g. "GMT" or other)

'

RFF (C1) REFERENCE (grp1)

+

c506.e1153 Reference Qualifier: Code "VON" (Loading Voyage
(M an..3) number, if different from the voyage number in the TDT-segment,
assigned by the Operating Carrier or his agent to the voyage of the
vessel).

:

c506.e1154 Reference Number: The Loading voyage number.
(R an..35)

'

FTX (C9) FREE TEXT (grp1)

+

e4451 Text Subject Qualifier: Allowed qualifiers:
(M an..17) "HAN" = Handling Instructions
"CLR" = Container Loading Remarks
"SIN" = Special instructions
"AAI" = General information
"ZZZ" = Mutually defined use

+

+

c108.e4440 Free Text: Description/Instructions/Remarks in plain
(M an..70) language or coded, for specific cargo/equipment. Codes, etc. to be
agreed between partners. One element with maximum field length 20
characters, unless agreed otherwise.

,

- N.B. 1) This segment is not generally machine processable. Use of this segment must be agreed between partners!**
- N.B. 2) This segment only to be used to transmit additional shipbounded information or instructions!**

This segment can be used for the following:

- a. "AAI" Description of general information, plain language or codes, as agreed between partners. Maximum 20 characters.
for example : name and telephone nr SCO planner
- b. "SIN" Additional information or instructions regarding special cargoes, equipment or breakbulk shipments.
- c. "HAN" For handling instructions the following codes are recommended:
"PLC" = Stowage is subject to pileweight
"MGM" = Minimum GM-value required

Group **grp2** (M9999) HAN - grp3

HAN (M1) Handling instruction (grp2)

+

c524.e4079 Handling Instruction, Coded: All codes Sequence
(M an..3) within the message must be:

- "DIS" = Discharge: Indicating all cells with containers/cargo to be discharged at the port of call. Regardless to previously given information.
- "SHI" = Shift: Indicating the cells with containers/cargo to be shifted. In general within the same bay and not via the quayarea, depending on the terminal agreement.
- "RES" = Restow: Indicating the cells with containers/cargo to be restowed. In general from one bay to another and likely via the quayarea, depending on the terminal agreement.
- "LOA" = Loading: Indicating the cells to be used for loading containers/cargo due to the given specifications.
- "COD" = Change of destination: Indicating the cells with containers of which the port of discharge has to be changed.
- "EXC" = Excess of stowage positions: Indicating the excess of cell positions due to last minut drops in relation to a "MOVINS" previously sent.
- "BAL" = Balance cell positions: Indicating additional cell positions to allow the SCO planner to have more space available because of an increase in bookings.
- "VOI" = Cell positions to be avoided: Indicating cell positions to be avoided due to damages, repair of cell guides, etc.

Principles:

The (DIS), (LOA), (COD), (EXC), (BAL) and (VOI) handling instructions will be indicated on cell by cell basis only.

Loading instruction: The main attribute will be the port of discharge, generally resulting in a number of cell positions which have to be loaded with containers /cargo for that port of discharge (destination).

For Dangerous cargo, Reefers and Specials the cell positions must be strictly followed.

Discharge instructions: This is resulting in cell positions for containers/ cargo to be discharged at the port of call.

The (RES) and (SHI) handling instructions can be indicated in two ways.

On cell by cell basis only, this way to be applied in case the container/cargo is to be moved to an obliged cell position.

From a cell to a bay or part of a bay, this method to be used in case the containers/ cargoes have to be moved to a certain range in the sense of a bay, a row or a tier.

Remarks:

If for the Shift handling no Reference qualifier has been given at all, then the container/ cargo may be reloaded in one of those cells/positions in the same bay which have already been indicated by general LOAD instructions for this bay.

If for the Restow handling no Reference qualifier has been given the container/cargo may be restowed in one of those cells/positions in a number of bays which have already been indicated by general LOAD instructions.

In chapter "4 Examples" there will be given a few examples about using the Handling instructions.

Group **grp3** (C9999) LOC - GID - GDS - FTX - MEA - DIM - TMP - RNG - LOC -
RFF - grp4 - grp5

LOC (M1) PLACE/LOCATION IDENTIFICATION (grp3)

+

e3227 Place/Location Qualifier: Code "147" (Stowage Cell)
(M an..3)

+

c517.e3225 Place/Location Identification: The actual location
(R an..25) Of the equipment or cargo on the vessel where upon the instruction
is related. The following formats are allowed:
1. ISO-format
2. Ro/Ro-format
3. Other non-ISO-format (to be agreed between partners)

1. ISO-format:

Bay/Row/Tier (BBRRTT). If Baynumber is less than 3 characters it
must be filled with leading zeroes, e.g. "0340210".

Hatch/Tier/Row (HHHTTRR) in case of ISO Feeder format. If Hatchnumber
is less than 3 characters it must be filled with leading zeroes.

2. Ro/Ro-format:

Deck/Bay/Row/Tier (DDBBRRTT).

:
:

c517.e3055 Code List Responsible Agency, coded: To indicate
(R an..3) which format is used. Valid codes are:
"5" = ISO-format
"87" = Ro/Ro-format, assigned by the Carrier
"ZZZ" = non-ISO-format, mutually defined

,

Remarks:

This LOC-segment is M1 and should not allow duplicate cell-locations for normal
height containers except following cases.

- a. In case flat rack containers stowed in one stowage location and not bundled,
they should be transmitted as individual units in the same stowage
location.
In case of bundles of flat rack containers in one stowage location the
number of the leading-unit should be given in the EQD-segment and the other
numbers in the EQA-segment. In such case MEA-segment must show the total
weight of containers. Otherwise you may duplicate LOC-segment with comment
showing bundled cargo in FTX segment (grp2).
- b. In case two half height containers stowed in one stowage location, Group
2 should be transmitted twice with the same stowage location.

GID (C1) GOODS ITEM DETAILS (grp3)

+

+

c213.e7224 Number of packages. The number of packages of non
(0 an..8) containerized cargo. If the cargo is Ro/Ro then the number "1"
used.

:

c213.e7065 Type of packages identification. Package type for
(0 an..7) noncontainerized cargo.

,

GDS (C1) GOODS DESCRIPTION (grp3)

+

c703.e7085 Nature of cargo, coded. Codes to be agreed between
(M an..3) partners.

,

Remarks: If this data is required, we recommend the use of the Harmonized Commodity Description and Coding System code list of cargo nature (HS). This codelist is:

"01"	=	Live animal
"06"	=	Live plant
"09"	=	Coffee
"10"	=	Wheat
"12"	=	Hay
"22"	=	Malt
"24"	=	Tobacco
"41"	=	Hide
"44"	=	Timber pack
"48"	=	Waste paper
"49"	=	News print
"52"	=	Cotton
"68"	=	Stone
"72"	=	Iron scrap

Further details can be given in the following FTX-segment, if required.

FTX (C9) FREE TEXT (grp3)

+

e4451 Text Subject Qualifier: Allowed qualifiers:
 (M an..3) "AAA" = Description of Goods
 "AAI" = General information
 "CLR" = Container Loading Remarks
 "HAN" = Handling Instructions
 "SIN" = Special instructions
 "TEM" = Temporary stowage
 "ZZZ" = Mutually defined use

+

+

+

c108.e4440 Free Text: Description/Instructions/Remarks in plain
 (M an..70) language or coded, for specific cargo/equipment. Codes, etc. to be
 agreed between partners. One element with maximum field length 20
 characters, unless agreed otherwise.

,

N.B. This segment is not generally machine processable. Use of this segment must be agreed between partners!

This segment can be used for the following:

"AAA":Description of goods, plain language or codes, as agreed between partners. Maximum 20 characters.

"SIN":Additional information or instructions regarding special cargoes, equipment or breakbulk shipments.

"HAN":For handling instructions the following codes are recommended:

"AB" Away from boiler (eng.room)
 "OD" Ondeck stowage
 "TS" Top stowage
 "UD" Under deck
 "UT" Under deck top
 "UW" Under waterline
 "OT" On decktop
 "EO" Except on decktop
 "OP" On deck protected
 "KC" Keep cool
 "AL" Away from living quarters
 "BC" Block stowage
 "AF" Away from foodstuffs
 "NO" Not overstay

"CLR":Container loading remarks: the following codes are recommended:

"BD" Bundled
 "DM" Damaged mt
 "SW" Sweeper
 "ER" Escort required
 "DR" Dry reefer
 "HT" Hangertainer
 "DO" Doors open
 "MB" Mailbox

MEA (M9) MEASUREMENTS (grp3)

+

e6311 Measurement Application Qualifier: Allowed qualifiers:
(M an..3) "WT" Grossweight
"TAR" Tare weight

+

+

c174.e6411 Measure Unit Qualifier: Allowed qualifiers:
(M an..3) "KGM" = kilogram = preferred
"LBR" = pounds

:

c174.e6314 Measurement Value: The grossweight (= actual tareweight
(D n..18) of the equipment plus its contents) in kilograms or pounds, as
qualified (no decimals). Tareweight of the equipment only, in case
of empty unit or breakbulk cargo.

:

c174.e6162 Range Minimum: The minimum grossweight of range of
(D n..18) shipments to be loaded/discharged in kilograms or pounds, as
qualified (no decimals).

:

c174.e6152 Range Maximum: The The maximum grossweight of range of
(D n..18) shipment to be loaded/discharged in kilograms or pounds, as qualified
(no decimals).

,

Remarks:

In case ranges are given (date-elements c174.e6162 end c174.6152) data-element
c174.e6314 is left out.

In case of an average weight, the values in minimum (c174.e6162) and maximum
(c174.e6152) are the same.

DIM (C9) DIMENSIONS (grp3)

+

e6145 Dimension Qualifier: Allowed qualifiers are:
 (M an..3) "1" = Gross dimensions (breakbulk)
 "5" = Off-standard dims. (overlength front)
 "6" = Off-standard dims. (overlength back)
 "7" = Off-standard dims. (overwidth right)
 "8" = Off-standard dims. (overwidth left)
 "9" = Off-standard dims. (overheight)
 "10" = External equipment dimensions (Non-ISO equipment)
 Basically allowed qualifier "1" for breakbulk cargo and from "5" to
 "9" for odd-sized-cargo. However allowed from "5" to "9" for
 breakbulk cargo as additional information, if required.

+

c211.e6411 Measure Unit Qualifier: Allowed qualifiers:
 (M an..3) "CMT" = Centimeters = preferred
 "INH" = Inches

:

c211.e6168 Length Dimension. Breakbulk length or overlength for
 (D n..15) containers, as qualified.

:

c211.e6140 Width Dimension: Breakbulk width or overwidth for
 (D n..15) containers, as qualified.

:

c211.e6008 Height Dimension: Breakbulk height or overheight for
 (D n..15) containers, as qualified.

,

N.B. This segment is only to be transmitted in case breakbulk, odd-sized-cargo and off-standard or non-ISO equipment is involved. In order to identify all relevant information, this segment may be repeated conditionally upto 9 times.

The codes 5-9 for odd-sized cargo only, carrying just the overdimensions. In case exact dimensions are not known at time of sending the message, the composite data-elements c211.e6168, c211.e6140 and c211.e6008 to be filled with the value 0 (zero).

TMP (C1) TEMPERATURE (grp3)

+

e6245 Temperature qualifier: Allowed qualifiers:
(M AN..3) "2" = Transport Temperature

+

c239.e6246 Temperature Setting: Actual temperature according to
(R n3) Reefer List (no deviation allowed) at which the cargo is to be
transported. For field format see remarks below.

:

c239.e6411 Measure Unit Qualifier: Allowed qualifiers:
(R an..3) "CEL" = degrees Celsius = Preferred.
"FAH" = degrees Fahrenheit

,

Remarks:

In case temperatures are not known at the time of sending the message, special handling of cooling/heating is indicated by mentioning the temperature qualifier only and leaving out the composite c239.

In spite of the field length of element c239.e6246 (temperature) is only N3, decimal mark and figure as well as negative values preceded by a sign (-) can be transmitted. Generally numeric data element values shall be regarded as positive unless they are preceded by a minus sign. The decimal mark and minus sign shall, however, not be counted as a character of the value when computing the maximum field length of a data element. Nevertheless, allowance has to be made for the character in transmission and reception.

Tenth of degrees have to be separated by a decimal point from full degrees (e.g. 18.5). Temperatures below zero have to be preceded by a minus sign (e.g. "-18.5", "-02.5"). The same applies for elements c280.e6162 and c280.6152 in the following RNG-segment.

For further explanation please refer to ISO 9735 "EDIFACT Application Level Syntax Rules", point 10 "Representation of numeric data element values".

RNG (C1) RANGE DETAILS (grp2)

+

e6167 Range Type Qualifier: Allowed qualifier:
(M an..3) "4" = Quantity range.

+

c280.e6411 Measure Unit Qualifier: Allowed qualifiers:
(M an..3) "CEL" = degrees Celsius
"FAH" = degrees Fahrenheit

:

c280.e6162 Range Minimum: Minimum temperature according to Reefer
(R n..18) List at which the cargo is to be transported.

:

c280.e6152 Range Maximum: Maximum temperature according to Reefer
(R n..18) List at which the cargo is to be transported.

'

Remarks:

Range minimum and maximum is only to be filled with different values in case it is allowed by the shipping line in charge of subject shipment, respectively the customer owing the goods. Otherwise c280.e6162 and c280.e6152 have to carry the same value. No deviation allowed.

LOC (M9) PLACE/LOCATION IDENTIFICATION (grp3)

+

e3227 Place/Location Qualifier: Allowed qualifiers:
 (M an..3) "9" = Port of Loading
 "11" = Port of discharge
 "13" = Transshipment port
 "64" = 1st optional port of discharge
 "68" = 2nd optional port of discharge
 "70" = 3rd optional port of discharge
 "80" = Original port of loading
 "83" = Place of delivery (to be used as final destination)
 "97" = Optional port of discharge.
 "152" = Next port of discharge

+

c517.e3225 Place/Location Identification: Namecode of the place/port, as
 (R an..25) qualified. Allowed codelists: UN-Locode or US-Census codes.
 Example codes: JPTYO = Tokyo
 USLAX = Los Angeles
 USOAK = Oakland
 USSEA = Seattle
 USCHI = Chicago
 For optional port of discharge (e3227 = "97"): "XXOPT".

:

c517.e1131 Code list qualifier. Allowed qualifiers:
 (O an..3) 139" = Port.

:

c517.e3055 Code list responsible agency, coded. Allowed codes:
 (O an..3) "112" = US, US Census Bureau, Schedule D for U S locations,
 Schedule K for foreign port locations.
 "6" = UN/ECE - United Nations - Economic Commission for
 Europe. (UN-Locodes).
 "ZZZ" = Optional ports.

+

c519.e3223 Related place/location one identification. The ISO
 (O an..25) country code.

:

c519.e1131 Code list qualifier. Allowed qualifier:
 (O an..3) "162" = Country.

:

c519.e3055 Code list responsible agency, coded. Allowed codes:
 (O an..3) "5" = ISO

+

c553.e3233 Related place/location two identification. The state or
 (O an..25) province code, postal abbreviations.

:

c553.e1131 Code list qualifier. Allowed qualifier:
(0 an..3) "163" = Country sub-entity; state or province.

,

Remarks:

1. If locodes other than UN-locodes are used the sender must verify with the recipient of the message if other than UN-locodes are acceptable/processable. Composites c519 and c553 are only relevant if no UN-locodes are used.
2. Minimum 2 ports to be given: loading port and discharging port.
3. Use of qualifiers, other than those for port of loading and port of discharge, must be agreed between partners.

RFF(1) (M9) REFERENCE (grp3)

+

c506.e1153 Reference Qualifier: Allowed qualifiers:
(M an..3) "BM" = B/L-number, as dummy, in case non of the following codes are applicable.
"ET" = Excess Transportation Number to be used for leading Stowage position, in case of Breakbulk or odd-sized-cargo.
"BN" = Booking reference number.
"CN" = Carrier's reference number.
"CV" = Container operator's reference number.
"BST" = Block stow to be used in case the carrier wants to indicate that blocks of containers must be delivered via train or into barge.
"ZZZ" = Mutually agreed.

:

c506.e1154 Reference Number: For Qualifiers :
(R an..35) "BM" = always "1".
"ZZZ" = always "1".
"ET" =: Leading stowage location, containing relevant data for this consignment.
"BN" = Booking reference number assigned by carrier or agent.
"CN" = Carrier's reference number.
"CV" = Container operator's reference number.
"BST" = Mode of transport assigned by the carrier.
1 = Feeder
2 = Rail
8 = Barge

'

N.B. For breakbulk and odd-sized-cargo see chapter 3: Special User Guidelines.

Example: RFF+BM:1' or RFF+ET+0120106'

RFF (2) (D1) REFERENCE (grp3)

+

c506.e1153 Reference Qualifier: Allowed qualifiers:
 (M an..3) "DSI" = Destination Stowge location ISO to be used as reference
 for Shift/Restow. To indicate the destination: Bay,
 Row,Tier or Cell.
 "DSF" = Destination Stowge location Feeder.
 "DSR" = Destination Stowge location RoRo.
 "DSZ" = Destination Stowge location Bilateral.

:

c506.e1154 Reference Number: For Qualifiers :
 (R an..35) "DSI" = Cell position BBBRRTT or
 Bay position BBB**** or
 Row position BBBRR** or
 Tier position BBB**TT

 "DSF" = Cell position H/T/R or
 Bay position H/** or
 Row position H*/R or
 Tier position H/T/*

 "DSR" = PAD number
 "DSZ" = To be agreed bilateral.

,

Remarks:

The second occurs of the RFF segment is only applicable for the handling instruction "RES" and "SHI". It is conditional. When not mentioned, the restow or shifters must meet the general load instructions. (see examples in chapter 4.)

Group **grp4** (C9) EQD - EQA - NAD

EQD (M1) EQUIPMENT DETAILS (grp4)

+

e8053 Equipment Qualifier: Allowed qualifiers:
 (M an..3) "CN" = Container
 "BB" = Breakbulk
 "TE" = Trailer
 "ZZZ" = Ro/Ro or otherwise

+

c237.e8260 Equipment Identification Number:
 (D an..17)

1. The containernumber:

Format: One continuous string with the identification, prefix and number. Examples: SCXU 2387653 must be transmitted as "SCXU2387653", EU 876 must be transmitted as "EU876". The number will be treated as a character string. E.g. alphanumeric check-digits can be transmitted here. If this segment is used the unique equipment identification number must always be transmitted, although this element is not mandatory!

2. Breakbulk: Leave blank in case of breakbulk.

3. Otherwise (Ro/Ro): The equipment identification number.

+

c224.e8155 Equipment Size and Type Identification: ISO size-type
 (D an..4) code of 4 digits (ISO 6346). Leave blank in case of breakbulk.
 For unknown ISO size/type codes the following codes may be used:

"4***"	=	Length = 40ft, rest unknown
"2***"	=	Length = 20ft, rest unknown
"42**"	=	40ft 8'6", rest unknown
"22**"	=	20ft 8'6", rest unknown
"40**"	=	40ft 8'0", rest unknown
"20**"	=	20ft 8'0", rest unknown

For type indications see the next examples. (the length is always mandatory):

"2*0*" = 20ft Dry-box, rest unknown

"4*2*" = 40ft Reefer, rest unknown

etc. etc.

Other codes to be agreed between partners.

:
:
:

c224.e8154 Equipment Size and Type: To indicate the length of the
 (D an..35) container in feet in relation to athwarts bays and non ISO length
 containers (45' ; 48' ; 52').

+

+

e8249 Equipment status, coded.
(O an..3) 6: Transhipment
 13: Tranship to other vessel
 15: Rail road transport
 16: Road transport
 17: Barge transport

+

e8169 Full/Empty Indicator, coded. Allowed codes:
(D an..3) "5" = Full
 "4" = Empty.
 Leave blank in case of breakbulk.

,

Remarks:

1. This segment to be qualified with "BB" in case of a breakbulk shipment, such as 'EQD+BB'. The segment will be followed directly by NAD-segment. The NAD-segment which can be used to transmit the actual carrier of the breakbulk.
2. Flats on which breakbulk will be stowed should be defined as 'empty'.
3. For a more detailed explanation of how to handle breakbulk shipments please refer to chapter 3, paragraph 3.1 "Breakbulk cargo".

EQA (C9) EQUIPMENT ATTACHED (grp4)

+

e8053 Equipment Qualifier: Allowed qualifiers:
(M an..3) "RG" = Reefer Generator
"CN" = Container
"CH" = Chassis

+

c237.e8260 Equipment Identification Number: The unitnumber.
(R an..17)

,

N.B. This segment may be used for transmission of attached equipment to container or for containers or other equipment stowed within one location with leading container in EQD (Platforms, Collapsible Flats, chassis, etc.).

NAD (C1) NAME AND ADDRESS (grp4)

+

e3035 Party Qualifier: Allowed code:
(M an..3) "CA" = Carrier of the cargo.
"CF" = Container operator

+

c082.e3039 Party Id Identification: Namecode of party to be billed for the
(M an..17) operation of subject equipment/cargo, if other than container
operator. This might be necessary to identify, in case operation,
e.g. restow, is caused due to a requirement from a party, which is
not the container operator, e.g. another line, sharing ships space
or the Terminal operator.

:
:

c082.e1131 Code List Qualifier: Qualifier "172".
(R an..3)

:

c082.e3055 Code List Responsible Agency, coded. Allowed codes:
(R an..3) "20" = BIC (Bureau International des Containeurs)
"166" = US National Motor Freight Classification Association (SCAC)
"ZZZ" = Mutually defined.

,

Group **grp5** (C999) DGS - FTX

DGS (M1) DANGEROUS GOODS (grp5)

+

e8273 Dangerous Goods Regulations: Code "IMD" (IMO IMDG Code)
(R an..3)

+

c205.e8351 Hazard Code Identification: IMDG Code, e.g. "1.2" or "8".
(M an..7)

:

c205.e8078 Hazard Substance/item/page number: The IMDG code page number (English
(O an..7) version).

+

c234.e7124 UNDG Number: UN number of respective dangerous cargo transported
(O n4) (4 digits).

+

c223.e7106 Shipment Flashpoint: the actual flashpoint in degrees Celsius or
(O n3) Fahrenheit. For inserting temperatures below zero or tenth degrees
please refer to remarks under TMP-segment respectively to ISO 9735.
If different dangerous goods with different flashpoints within one
load to be transported, only the lowest flashpoint should be
inserted.

:

c223.e6411 Measure Unit Qualifier: Allowed qualifiers:
(O an..3) "CEL" = degrees Celsius = Preferred
"FAH" = degrees Fahrenheit

+

e8339 Packing group, coded: The packing group code of the hazardous goods.
(O an..3)

+

e8364 EMS number: Emergency schedule number.
(O an..6)

+

e8410 MFAG: Medical First Aid Guide number.
(O an..4)

+

+

c235.e8158 Hazard Identification number, upper part.
(O an..4)

:

c235.e8186 Substance Identification number, lower part.
(O an4)

+

c236.e8246 Dangerous Goods Label Marking (1).
(O an..4) See below for possible use of this data element.

:

c236.e8246 Dangerous Goods Label Marking (2).
(O an..4)

:

c236.e8246 Dangerous Goods Label Marking (3).
(O an..4)

,

N.B. Use of this segment must be agreed between partners.

Possible use of data elements c.236.e8246 (1, 2 and 3):
IMDG Code list of dangerous goods sub label:

Subsidiary risk	sub label	code
Explosive	Explosive	1
Gas	Flammable gas	2.1
Gas	Non-flammable compressed gas	2.2
Gas	Poison gas	2.3
Flammable liquid	Flammable liquid F.P.<-18C	3.1
Flammable liquid	Flammable liquid F.P.-18C till 23C	3.2
Flammable liquid	Flammable liquid	
	F.P.23C upto/incl 61C	3.3
Flammable solid	Flammable solid	4.1
Flammable solid	Spontaneously combustible	4.2
Flammable solid	Dangerous when wet	4.3
Oxidizing agent	Oxidizing agent	5.1
Oxidizing agent	Oxidizing peroxide	5.2
Poison	Poison	6.1
Poison	Harmful	6.1 HFL
Poison	Infectious substance	6.2
Radio active	Radio active - cat 1	7
Radio active	Radio active - cat 2	7
Radio active	Radio active - cat 3	7
Corrosive	Corrosive	8
Misellaneous	Miscellaneous	9

FTX (C1) FREE TEXT (grp5)

+

e4451 Text Subject Qualifier. Allowed qualifiers:
(M an..3) "AAC" = Dangerous goods additional information
"AAD" = Dangerous goods, technical name, proper shipping name.

+

+

+

c108.e4440 Free text: Description of hazard material in plain language.
(M an..70) One element of maximum 70 characters to be given only for the
(1) description. Transmit the text "NIL", if no description is available
and one or both of the following data elements must be transmitted.

:

c108.e4440 Free text: The net weight in kilos of the hazardous material to be
(O an..70) transmitted here.
(2)

:

c108.e4440 Free text: The DG-reference number as allocated by the central
(O an..70) planner, if known.
(3)

,

N.B. Use of this segment must be agreed between partners.

UNT (M1) MESSAGE TRAILER

+

e0074 Number of segments in the message, including UNH and UNT segments,
(M n..6) but excluding UNA, UNB and UNZ segments.

+

e0062 Message reference number: This reference must be identical to the
(M an..14) reference in the UNH-segment (e0062).

,

UNZ (M1) INTERCHANGE TRAILER

+

e0036 Interchange Control Count: The number of messages in the interchange.
(M n..6)

+

e0020 Interchange Control Reference: This reference must be identical to
(M an..14) the reference in the UNB-segment (e0020).

,

5. SPECIAL USER GUIDELINES

5.1. Odd-sized cargo

All information concerning the cargo should be mentioned on stowage location where the equipment is stowed, with reference to the additionally occupied stowage locations due to the nature of cargo, if needed, in the RFF segment of group 3. Please see subject segment c506.e1154 .

Cargo is to be identified as over-sized in segment FTX of group 3.

In reverse, stowage location(s) occupied due to over-size will just carry the handling instructions (HAN) and the position number (LOC) as well as the reference to the "Leading Stowage Position" as above, in segment RFF (c506.e1154). The "Leading Stowage Position" is where the equipment will be or has been stowed. The leading cell position has been defined as the lowest cell position.

Dimensions have to be inserted according to instructions mentioned under the segment DIM.

5.2. Breakbulk cargo (B/B)

Principle:

The handling instruction, triggered by HAN **grp2** is valid for both the break bulk cargo as well as the accompanying equipment. Therefor the occupied cellposition in the LOC segment will be reported two times. This method will supply full freedom to describe any combination of break bulk and equipment.

All relevant information concerning the cargo has to be referred to the "Leading Stowage Position" which is the first relevant cellposition mentioned after the Handling instruction.

The "leading Stowage Position" to be defined as the lowest cellnumber of the necessary cellpositions.

Segment RFF carries qualifier "ET" in e1153 and stowage position in e1154 (as reference to the leading cellposition) in case more than one cell will be occupied by a piece.

Segment EQD carries qualifier "BB" in e8053 and the break bulk reference in e8260. The format of the break bulk reference is: UN-Locode of POL concatenated with a five digit number, e.g. "DEHAM00001", "NLRMTM48901". This reference number is to be generated by the party which inserts the break bulk piece into the message. The number must not be modified even if this piece has been or will be restowed.

The other cellpositions to be occupied will just carry the cellposition number and reference to the "Leading Stowage Position" in segment RFF and the reference to the break bulk reference in segment EQD.

This is to be done for every single piece of break bulk.

Possibly used equipment (flatrack or platform) has to be described as any other container.

Thus, in case of so-called "Sandwich-Stow" (Flat and Platform in one position) there have to be two occurrences of **grp3** for the used equipment (in addition of the **grp3** which describes the break bulk).

Stowage locations occupied due to odd-sized cargo will be handled as described under **Odd-sized cargo**

See next pages for a detailed description of some examples.

6. EXAMPLES

6.1. BREAKBULK

Example # 1: Breakbulk piece without any equipment.

Instruction: Load 1 piece of machinery, 32500 kos, 890x550x320 cm in Hamburg to Singapore on Bay 12 Deck, Rows 00,02,04 and Tier 82

N.B. Cell 120082 is the leading cell position because it is the lowest cell number.

EDIFACT:	Comment:
HAN+LOA'	Handling instuction to load
<u>The breakbulk piece:</u>	
LOC+147+0120082::5'	Leading cell position
FTX+AAA+++1 PIECE MACHINERY'	It is breakbulk
FTX+HAN+OD'	On deck stow
MEA+WT++KGM:32500'	Weight of the cargo
DIM+1+CMT:890550:320'	Measurements
DIM+9+CMT	Overheight indication
LOC+6+DEHAM'	Load port
LOC+11+SGSIN'	Discharge port
RFF+ET+0120082'	Reference to leading cell position
EQD+BB+DEHAM00001'	BreakBulk reference number
NAD+CA+ABC'	Carrier of the uncon piece
<u>Additional slots occupied by the breakbulk piece:</u>	
LOC+147+0120282::5'	Next cell occupied by the piece
LOC+6+DEHAM'	Mandatory segment
RFF+ET+0120082'	Reference to leading cell position
EQD+BB+DEHAM00001'	BreakBulk reference number
LOC+147+0120482::5'	Next cell occupied by the piece
LOC+6+DEHAM'	Mandatory segment
RFF+ET+0120082'	Reference to leading cell position
EQD+BB+DEHAM00001'	BreakBulk reference number

Example # 2: Two pieces Breakbulk without any equipment. Sharing the same slots; one piece is overheight.

Instruction: Load 1 piece of machinery 32500 kos, 890x550x320cm, in Hamburg to Singapore in Bay 12 Hold , Rows 00,02,04 and Tier 14, which is overheight.

Load 1 piece of machinery 25000 kos, 550x250x108, in Hamburg to Hongkong in Bay 12, Rows 00,02,04 and Tier 14.

EDIFACT:**Comment:**

HAN+LOA'

Handling instruction to load

The first breakbulk piece:

LOC+147+0120014::5'
 FTX+AAA+++1 PIECE MACHINERY'
 FTX+SIN+++OVERHEIGHT'
 MEA+WT++KGM:32500'
 DIM+1+CMT:890:550:320'
 DIM+9+CMT:::065'
 LOC+6+DEHAM'
 LOC+11+SGSIN'
 RFF+ET+01200014'
 EQD+BB+DEHAM00002'
 NAD+CA+ABC'

Leading cell position of first breakbulk piece
 It is breakbulk
 Extra remark as special instruction
 Weight of the cargo
 Measurements
 Overheight dimension
 Load port
 Discharge port
 Reference to leading cell position
 BreakBulk reference number
 Carrier of the uncon piece

Additional slots occupied by the breakbulk piece:

LOC+147+0120214::5'
 DIM+9+CMT:::065'
 LOC+6+DEHAM'
 RFF+ET+0120014'
 EQD+BB+DEHAM00002'
 LOC+147+0120414::5'
 DIM+9+CMT:::065'
 LOC+6+DEHAM'
 RFF+ET+0120014'
 EQD+BB+DEHAM00002'

Next cell occupied by the piece
 Overheight dimension
 Mandatory segment
 Reference to leading cell position
 BreakBulk reference number
 Next cell occupied by the piece
 Overheight dimension
 Mandatory segment
 Reference to leading cell position
 BreakBulk reference number

The second breakbulk piece:

LOC+147+0120014::5'
 FTX+AAA+++1 PIECE MACHINERY'
 MEA+WT++KGM:25000'
 DIM+1+CM:550:250:108'
 LOC+6+DEHAM'
 LOC+11+HKHKG'
 RFF+ET+0120014'
 EQD+BB+DEHAM00003'
 NAD+CA+XYZ'

Leading cell position of second breakbulk piece
 It is breakbulk
 Weight of the cargo
 Measurements
 Load port
 Discharge port
 Reference to leading cell position
 BreakBulk reference number
 Carrier of the uncon piece

Additional slots occupied by the breakbulk piece:

LOC+147+0120214::5'
 LOC+6+DEHAM'
 RFF+ET+0120014'
 EQD+BB+DEHAM00003'
 LOC+147+0120414::5'
 LOC+6+DEHAM'
 RFF+ET+0120014'
 EQD+BB+DEHAM00003'

Next cell occupied by the piece
 Mandatory segment
 Reference to leading cell position
 BreakBulk reference number
 Next cell occupied by the piece
 Mandatory segment
 Reference to leading cell position
 BreakBulk reference number

Example # 3: One breakbulk piece with equipment

Instruction: Load 1 piece of machinery 32500 kos, 890x550x320cm, from Hamburg to Singapore in Bay 12 Hold , Rows 00,02,04 and Tier 14.

The piece of machinery to be loaded on 3 flats, ex Hamburg, numbers ECTU4235876, ECTU 4246733, ECTU 4248891 with a tareweight of 4250 kos each. Flat ECTU4248891 to be discharged in Singapore the other two flats to be discharged in Tokyo.

EDIFACT:**Comment:**

HAN+LOA'

Handling instruction to load

The breakbulk piece:

LOC+147+0120014::5'	Leading cell position
FTX+AAA+++1 PIECE MACHINERY'	It is breakbulk
FTX+SIN+++OVERHEIGHT'	Extra remark as special instruction
MEA+WT++KGM:32500'	Weight of the cargo
DIM+1+CMT:890:550:320'	Measurements
DIM+9+CMT:::065'	Overheight dimension
LOC+6+DEHAM'	Load port
LOC+11+SGSIN'	Discharge port
RFF+ET+0120014'	Reference to leading cell position
EQD+BB+DEHAM00004'	BreakBulk reference number
NAD+CA+ABC'	Carrier of the uncon piece

Additional slots occupied by the breakbulk piece:

LOC+147+0120214::5'	Next cell occupied by the piece
DIM+9+CMT:::065	Overheight dimension
LOC+6+DEHAM'	Mandatory segment
RFF+ET+0120014'	Reference to leading cell position
EQD+BB+DEHAM00004'	BreakBulk reference number
LOC+147+0120414::5'	Next cell occupied by the piece
DIM+9+CMT:::065'	Overheight dimension
LOC+6+DEHAM'	Mandatory segment
RFF+ET+0120014'	Reference to leading cell position
EQD+BB+DEHAM00004'	BreakBulk reference number

Supporting flatracks:

LOC+147+0120014::5'	Cell position of first flat
MEA+WT++KGM:4250'	Weight of the flat
LOC+6+DEHAM'	Load port
LOC+11+SGSIN'	Discharge port
RFF+BM:1'	Dummy segment
EQD+CN+ECTU 4248891+4361+++4'	Flat details
NAD+CF+ABC:172'	Container operator of the flat
LOC+147+0120214::5'	Cell position of second flat
MEA+WT++KGM:4250'	Weight of the flat
LOC+6+DEHAM'	Load port
LOC+11+JPTYO'	Discharge port
RFF+BM:1'	Dummy segment
EQD+CN+ECTU 4246733+4361+++4'	Flat details
NAD+CF+XYZ:172'	Container operator of the flat
LOC+147+0120414::5'	Cell position of third flat
MEA+WT++KGM:4250'	Weight of the flat
LOC+6+DEHAM'	Load port
LOC+11+JPTYO'	Discharge port
RFF+BM:1'	Dummy segment
EQD+CN+ECTU 4248891+4361+++4'	Flat details
NAD+CF+PRQ:172'	Container operator of the flat

Example # 4: One piece breakbulk on platforms with upside down flatracks on top of it

Instruction: Load 1 piece of machinery 105000 kos, 890x550x190cm, from Hamburg to Singapore in Bay 12 Hold , Rows 00,02,04 and Tier 04.
 The piece of machinery to be loaded on 3 flats, ex Hamburg, on top of machinery, 3 upside down flatracks to be loaded.
 Platform and flatracks to be discharged at Singapore.

EDIFACT:**Comment:**

HAN+LOA'

Handling instruction to load

The breakbulk piece:

LOC+147+0120004::5'	Leading cell position
FTX+AAA+++1 PIECE MACHINERY'	It is breakbulk
MEA+WT++KGM:105000'	Weight of the cargo
DIM+1+CM:890:550:190'	Measurements
LOC+6+DEHAM'	Load port
LOC+11+SGSIN'	Discharge port
RFF+ET+0120004'	Reference to leading cell position
EQD+BB+DEHAM00005'	BreakBulk reference number
NAD+CA+ABC'	Carrier of the uncon piece

Additional slots occupied by the breakbulk piece:

LOC+147+0120204::5'	Next cell occupied by the piece
MEA+WT++KGM:0'	Dummy segment
LOC+6+DEHAM'	Mandatory segment
RFF+ET+0120004'	Reference to leading cell position
EQD+BB+DEHAM00005'	BreakBulk reference number
LOC+147+0120404::5'	Next cell occupied by the piece
MEA+WT++KGM:0'	Dummy segment
LOC+6+DEHAM'	Mandatory segment
RFF+ET+0120004'	Reference to leading cell position
EQD+BB+DEHAM00005'	BreakBulk reference number

Supporting platforms:

LOC+147+0120004::5'	Cell position of first platform
MEA+WT++KGM:3200'	Weight of the platform
LOC+6+DEHAM'	Load port
LOC+11+SGSIN'	Discharge port
RFF+BM:1'	Dummy segment
EQD+CN+HALO 4248891+4960+++4'	Platform details
NAD+CF+ABC:172'	Container operator of the platform
LOC+147+0120204::5'	Cell position of second platform
MEA+WT++KGM:3200'	Weight of the platform
LOC+6+DEHAM'	Load port
LOC+11+SGSIN'	Discharge port
RFF+BM:1'	Dummy segment
EQD+CN+HALO 4246733+4960+++4'	Platform details
NAD+CF+XYZ:172'	Container operator of the platform
LOC+147+0120404::5'	Cell position of third platform
MEA+WT++KGM:3200'	Weight of the platform
LOC+6+DEHAM'	Load port
LOC+11+SGSIN'	Discharge port
RFF+BM:1'	Dummy segment
EQD+CN+HALO 4248891+4960+++4'	Platform details
NAD+CF+PRQ:172'	Container operator of the platform

Supporting flats:

LOC+147+0120004::5'	Cell position of first flat
FTX+CLR+++UPSIDE DOWN'	Optional remark
MEA+WT++KGM:3250'	Weight of the flat
LOC+6+DEHAM'	Load port
LOC+11+SGSIN'	Discharge port
RFF+BM:1'	Dummy segment
EQD+CN+ECTU 4248891+4361+++4'	Flat details
NAD+CF+ABC:172'	Container operator of the flat
LOC+147+0120204::5'	Cell position of second flat
FTX+CLR+++UPSIDE DOWN'	Optional remark
MEA+WT++KGM:3250'	Weight of the flat
LOC+6+DEHAM'	Load port
LOC+11+SGSIN'	Discharge port
RFF+BM:1'	Dummy segment
EQD+CN+ECTU 4246733+4361+++4'	Flat details
NAD+CF+XYZ:172'	Container operator of the flat
LOC+147+0120404::5'	Cell position of third flat
FTX+CLR+++UPSIDE DOWN'	Optional remark
MEA+WT++KGM:3250'	Weight of the flat
LOC+6+DEHAM'	Load port
LOC+11+SGSIN'	Discharge port
RFF+BM:1'	Dummy segment
EQD+CN+ECTU 4248891+4361+++4'	Flat details
NAD+CF+PRQ:172'	Container operator of the flat

6.2 CONTAINER HANDLING INSTRUCTIONS

Example # 1: DIS

Instruction: Discharge all containers from bay 21 for Rotterdam and Antwerp (15 x Rotterdam and 5 x Antwerp).

EDIFACT:	Comment:
HAN+DIS'	Discharge instruction
LOC+147+0210302::5'	From cell position
LOC+11+BEANT'	Previously for Antwerp
RFF+BM:1'	
LOC+147+0210301::5'	Same
LOC+11+BEANT'	
RFF+BM:1'	
etc. for the rest of the 3 Antwerp containers	
LOC+147+0210304::5'	From cell position
LOC+11+NLRTM'	Originally for Rotterdam
RFF+BM:1'	
LOC+147+0210104::5'	
LOC+11+NLRTM	
RFF+BM:1'	
etc. for the rest of the 13 Rotterdam containers	

Example # 2: LOA

Instruction: Load 20 full containers (20') for Tokyo in Bay 21 Hold, rows 00-04, tiers 02-08; and in cell positions 21-04-02 and 21-04-04 two times IMO 6.1 with refnr DUB215.

EDIFACT:	Comment:
HAN+LOA'	Load instruction
LOC+147+0210302::5'	For cell position
LOC+11+JPTYO'	Destination Tokyo
RFF+BM:1'	
EQD+CN++2200+++5'	Type dry box 20'
LOC+147+0210102::5'	Same
LOC+11+JPTYO'	
RFF+BM:1'	
EQD+CN++2200+++5'	
etc. for the rest of non special cargo	
LOC+147+0210402::5'	For cell position
LOC+11+JPTYO'	Destination Tokyo
RFF+BN:DUB215'	For the given refnr
EQD+CN++2200+++5'	Dry box 20'
DGS+IMD+6.1'	For imo class 6.1

LOC+147+0210404::5' Same
LOC+11+JPTYO'
RFF+BN:DUB215'
EQD+CN++2200+++5'
DGS+IMD+6.1'

Example # 3: SHI

Instruction: Shift container HLCU8877661 from cell 0330812 to 0330712.

EDIFACT:	Comment:
HAN+SHI'	Shift instruction
LOC+147+0330812::5'	Original cell position
LOC+11+BEANT'	
RFF+BM:1'	
RFF+DSI:0330712'	New cell position
EQD+CN+HLCU 8877661'	Containernumber
NAD+CF+HLC:172:20'	Party to be billed

N.B.

LOA-instruction for Antwerp for this cell position must be given separately, i.e.

```
HAN+LOA'
LOC+147+0330712::5'
LOC+11+BEANT'
RFF+BM:1'
```

Remarks:

If the second RFF segment has **not been** given this container is to be loaded in one of the cell positions within the same bay. For which already a general load instruction (available for antwerp cargo) has been given. These may be instructed as follows:

HAN+LOA'	Container to be reloaded
LOC+147+0330712::5'	in one of those general
LOC+11+BEANT'	cell positions, mentioned
RFF+BM:1'	in this load instruction.
LOC+147+0330710::5'	
LOC+11+BEANT'	
RFF+BM:1'	
LOC+147+0330708::5'	
LOC+11+BEANT'	
RFF+BM:1'	

Example # 4: RES

Instruction: Restow 9 x 20' NYORK Bay 17 Hold to Bay 41 rows 01,03,05 and tiers 06/08.

EDIFACT:**Comment:**

HAN+RES'	Restowage instruction
LOC+147+0170104::5'	for this cell position
LOC+11+USNYC'	
RFF+BM:1'	
RFF+DSI+041****'	To Bay 041
EQD+CN:NYKU 1234567'	
NAD+CF+NYK:172:20'	Party to be billed
LOC+147+0170004::5'	Same
LOC+11+USNYC'	
RFF+BM:1'	
RFF+DSI:041****'	
EQD+CN:NYKU 8877665	
NAD+CF+NYK:172:20'	

etc. for the rest of the 7 original cell positions + the container numbers.

N.B.

LOA-instruction for 20' New York for these cell positions must be given separately, i.e.

HAN+LOA'
LOC+147+0410106::5'
LOC+11+USNYC'
RFF+BM:1'
LOC+147+0410306::5'
LOC+11+USNYC'
RFF+BM:1'
LOC+147+0410506::5'
LOC+11+USNYC'
RFF+BM:1'

etc. for the rest of another 6 cell positions within bay 041.

Remarks:

If the second RFF segment has **not been** given, the containers may be restowed in one of those cell positions in the bays, indicated by general load instructions for 20' New York; these may be instructed as follows:

HAN+LOA'	5 containers to be restowed
LOC+147+0410106::5'	within bay 041 Hold, in the
LOC+11+USNYC'	5 indicated cell positions.
RFF+BM:1'	
EQD+CN++2200+++5'	
LOC+147+0410306'	
LOC+11+USNYC'	
RFF+BM:1'	
EQD+CN++2200+++5'	

etc. followed by e.g. another 3 cell positions for N.Y. within bay 041

and

LOC+147+0470282::5'	4 containers to be restowed
---------------------	-----------------------------

Example # 5: COD

N.B.: Only to be used for a change of destination WITHOUT a physical move.

Instruction: For the Port of Antwerp to change POD of containers in Bay 19 Hold,
Rows 00-02, Tiers 02-12 from Singapore into Hongkong.

EDIFACT:**Comment:**

HAN+COD'	COD instruction
LOC+147+0190002::5'	For cell position
LOC+11+HKHKG'	Changed destination Hongkong
RFF+BM:1'	
EQD+CN+AVDU 1234567++++5'	Container number is obliged
LOC+147+0190102::5'	For cell position
LOC+11+HKHKG'	Changed destination Hongkong
RFF+BM:1'	
EQD+CN+AVDU 1234568++++5'	Container number is obliged
LOC+147+0190202::5'	For cell position
LOC+11+HKHKG'	Changed destination Hongkong
RFF+BM:1'	
EQD+CN+AVDU 1234569++++5'	Container number is obliged

etc for the next 15 containers

Example # 6: EXC

Instruction: Due to expected drops in bookings, cut all positions in Bay 41 Hold,
Rows 07-10, Tiers 02-10

EDIFACT:**Comment:**

HAN+EXC'	EXCESS
LOC+147+0410702::5'	cell position
LOC+11+JPTYO'	Destination Tokyo
RFF+BM:1'	
LOC+147+0410802::5'	cell position
LOC+11+ JPTYO'	destination Tokyo
RFF+BM:1'	
LOC+147+0410704::5	cell position
LOC+11+JPTYO'	destination Tokyo
RFF+BM:1'	
LOC+147+0410804::5	cell position
LOC+11+JPTYO'	destination Tokyo
RFF+BM:1'	
LOC+147+0410904::5	cell position
LOC+11+JPTYO'	destination Tokyo
RFF+BM:1'	
LOC+147+0411004::5	cell position
LOC+11+JPTYO'	destination Tokyo
RFF+BM:1'	

etc. for the rest of 12containers in EXCESS

Example # 7: BAL

Instruction: Keep as balance bay 33 Hold, Rows 00-04, Tiers 10-16 for 20' dry box containers with destination Penang and /or Singapore

EDIFACT:	Comment:
HAN+BAL'	Balance positions if more space is required
LOC+147+0330310::5'	Cell position
LOC+11+MYPEN'	Penang balance
RFF+BM+1'	
LOC+147+0330110::5'	Cell position
LOC+11+MYPEN'	Penang balance
RFF+BM+1'	
LOC+147+0330010::5'	Cell position
LOC+11+MYPEN'	Penang balance
RFF+BM+1'	

etc for the rest of the 17 balance positions for Penang

LOC+147+0330310::5'	Cell position
LOC+11+SGSIN'	Singapore balance
RFF+BM+1'	
LOC+147+0330110::5'	Cell position
LOC+11+SGSIN'	Singapore balance
RFF+BM+1'	
LOC+147+0330010::5'	Cell position
LOC+11+SGSIN'	Singapore balance
RFF+BM+1'	

etc for the rest of the 17 balance positions for Singapore

Example # 8: VOI

Instruction: Bay 43 Hold, Rows 08-10, Tiers 02-06 to be avoided due to damaged cell guides.

EDIFACT:	Comment:
HAN+VOI	To be avoided
LOC+147+0430802::5'	Cell position
LOC+11+BEANT	Mandatory segment
RFF+BM:1'	
LOC+147+0430804::5'	Cell position
LOC+11+BEANT	Mandatory segment
RFF+BM:1"	

etc

Example # 9: Loading with UNKNOWN WEIGHT

Instruction: Load 7x20' containers for New York in Bay 31 Hold, Row 10, DG-IMO
6.1 Booking Ref nr RDM 210, weight UNKNOWN.

EDIFACT:**Comment:**

HAN+LOA'	Handling instruction load
LOC+147+0311004::5'	Cell position
LOC+11+USNYC'	Destination port
RFF+BN+RDM210'	Booking ref. nr.
RFF+DSI::02110**	Obliged row 10
DGS+IMD+6.1'	Imo class
LOC+147+0311006::5'	Cell position
LOC+11+USNYC'	Destination port
RFF+BN+RDM210'	Booking refnr.
RFF+DSI::02110**	Obliged row 10.
DGS+IMD+6.1'	Imo class
LOC+147+0311008::5'	Cell position
LOC+11+USNYC'	Destination port
RFF+BN+RDM210'	Booking ref. nr.
RFF+DSI::02110**	Obliged row 10
DES+IMD+6.1'	Imo class

etc for the rest of another 4 cellpositions in row 10.

7. EXAMPLE MESSAGE

The segments of the example message are all shown on separate lines. In accordance with the Edifact Syntax Rules, however, no Carriage Returns (CR) and/or Line Feeds (LF) must be transmitted.

Example follows.

This page is reserved for the example message

8. MESSAGE STRUCTURE DIAGRAM

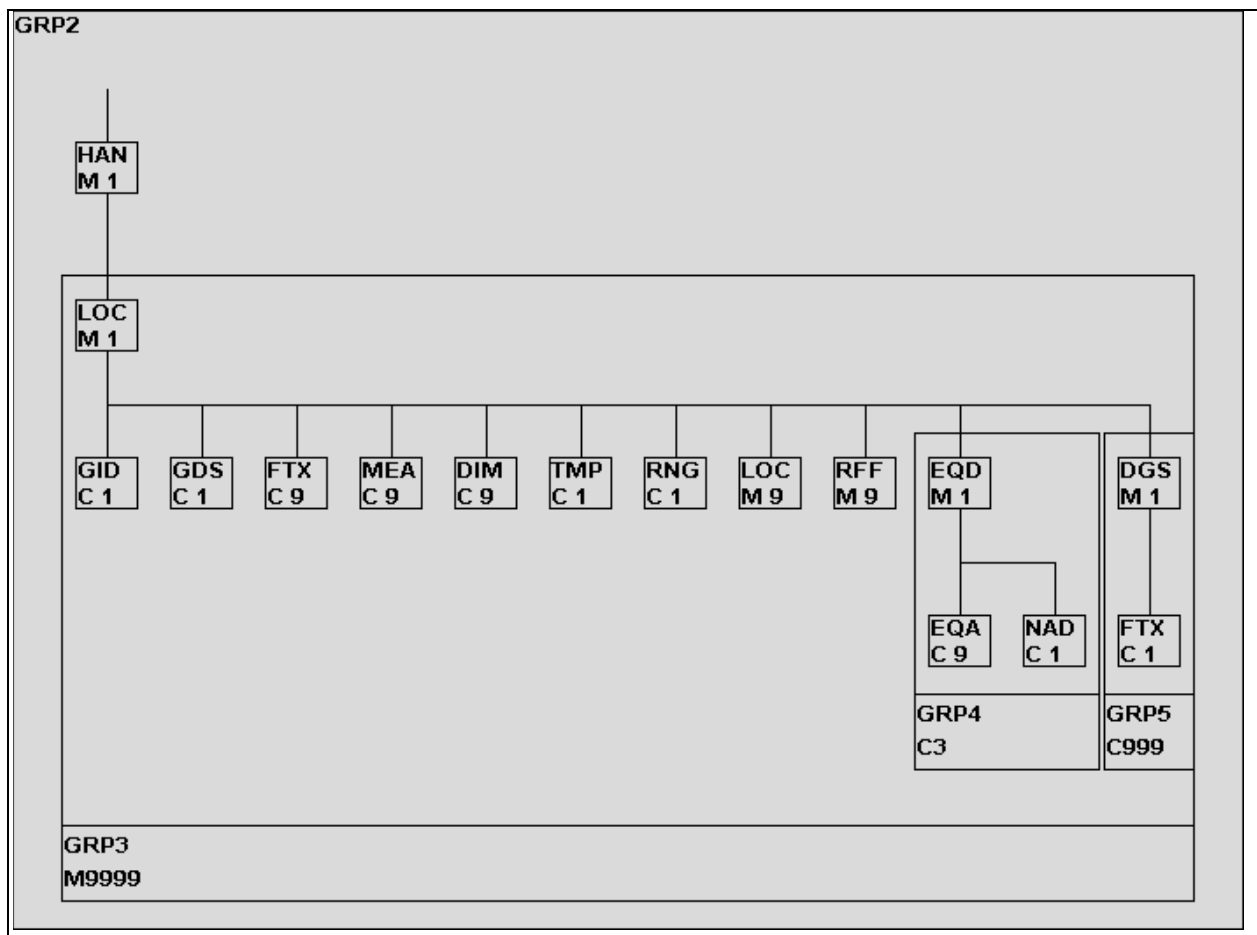
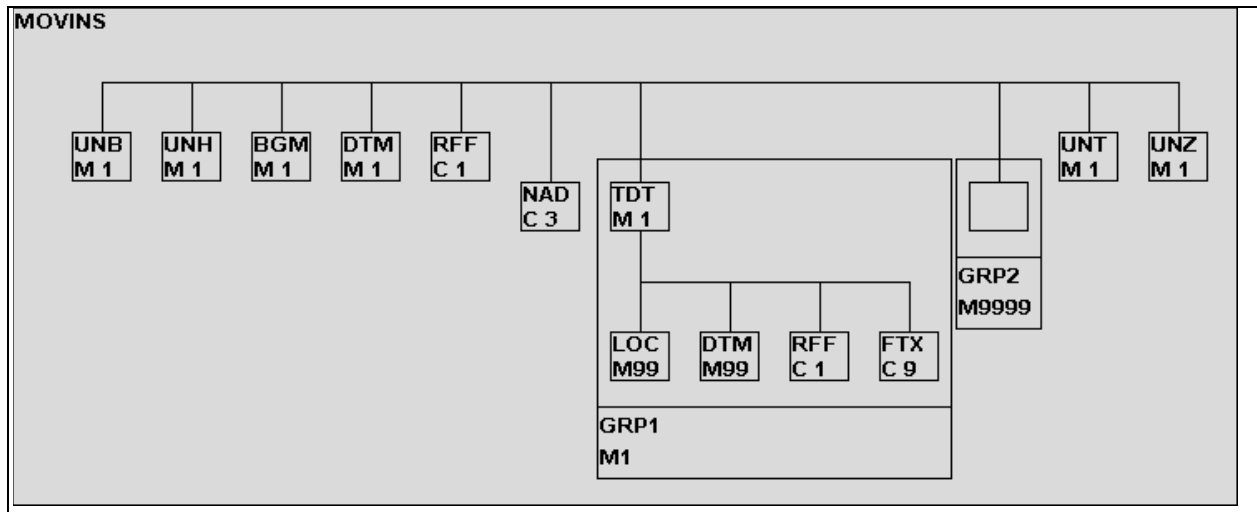

This page is left blank intentionally

9. SEGMENT DIRECTORY (D.95B)**BGM BEGINNING OF MESSAGE**

To indicate the type and function of a message and to transmit the identifying number.

C002	DOCUMENT/MESSAGE NAME	C	
1001	DOCUMENT/MESSAGE NAME, CODED	C	AN..3
1131	CODE LIST QUALIFIER	C	AN..3
3055	CODE LIST RESPONSIBLE AGENCY, CODED	C	AN..3
1000	DOCUMENT/MESSAGE NAME	C	AN..35
1004	DOCUMENT/MESSAGE NUMBER	C	AN..35
1225	MESSAGE FUNCTION, CODED	C	AN..3
4343	RESPONSE TYPE, CODED	C	AN..3

DGS DANGEROUS GOODS

To identify dangerous goods.

8273	DANGEROUS GOODS REGULATIONS, CODED	C	AN..3
C205	HAZARD CODE	C	
8351	HAZARD CODE IDENTIFICATION	M	AN..7
8078	HAZARD SUBSTANCE/ITEM/PAGE NUMBER	C	AN..7
8092	HAZARD CODE VERSION NUMBER	C	AN..10
C234	UNDG INFORMATION	C	
7124	UNDG NUMBER	C	N4
7088	DANGEROUS GOODS FLASHPOINT	C	AN..8
C223	DANGEROUS GOODS SHIPMENT FLASHPOINT	C	
7106	SHIPMENT FLASHPOINT	C	N3
6411	MEASURE UNIT QUALIFIER	C	AN..3
8339	PACKING GROUP, CODED	C	AN..3
8364	EMS NUMBER	C	AN..6
8410	MFAG	C	AN..4
8126	TREM CARD NUMBER	C	AN..10
C235	HAZARD IDENTIFICATION	C	
8158	HAZARD IDENTIFICATION NUMBER, UPPER PART	C	AN..4
8186	SUBSTANCE IDENTIFICATION NUMBER, LOWER PART	C	AN4
C236	DANGEROUS GOODS LABEL	C	
8246	DANGEROUS GOODS LABEL MARKING	C	AN..4
8246	DANGEROUS GOODS LABEL MARKING	C	AN..4
8246	DANGEROUS GOODS LABEL MARKING	C	AN..4
8255	PACKING INSTRUCTION, CODED	C	AN..3
8325	CATEGORY OF MEANS OF TRANSPORT, CODED	C	AN..3
8211	PERMISSION FOR TRANSPORT, CODED	C	AN..3

DIM DIMENSIONS

To specify dimensions.

6145	DIMENSION QUALIFIER	M	AN..3
C211	DIMENSIONS	M	
6411	MEASURE UNIT QUALIFIER	M	AN..3
6168	LENGTH DIMENSION	C	N..15
6140	WIDTH DIMENSION	C	N..15
6008	HEIGHT DIMENSION	C	N..15

DTM DATE/TIME/PERIOD

To specify date, time, period.

C507	DATE/TIME/PERIOD	M	
2005	DATE/TIME/PERIOD QUALIFIER	M	AN..3
2380	DATE/TIME/PERIOD	C	AN..35
2379	DATE/TIME/PERIOD FORMAT QUALIFIER	C	AN..3

EQA ATTACHED EQUIPMENT

To specify attached or related equipment.

8053	EQUIPMENT QUALIFIER	M	AN..3
C237	EQUIPMENT IDENTIFICATION	C	
8260	EQUIPMENT IDENTIFICATION NUMBER	C	AN..17
1131	CODE LIST QUALIFIER	C	AN..3
3055	CODE LIST RESPONSIBLE AGENCY, CODED	C	AN..3
3207	COUNTRY, CODED	C	AN..3

EQD EQUIPMENT DETAILS

To identify a unit of equipment.

8053	EQUIPMENT QUALIFIER	M	AN..3
C237	EQUIPMENT IDENTIFICATION	C	
8260	EQUIPMENT IDENTIFICATION NUMBER	C	AN..17
1131	CODE LIST QUALIFIER	C	AN..3
3055	CODE LIST RESPONSIBLE AGENCY, CODED	C	AN..3
3207	COUNTRY, CODED	C	AN..3
C224	EQUIPMENT SIZE AND TYPE	C	
8155	EQUIPMENT SIZE AND TYPE IDENTIFICATION	C	AN..10
1131	CODE LIST QUALIFIER	C	AN..3
3055	CODE LIST RESPONSIBLE AGENCY, CODED	C	AN..3
8154	EQUIPMENT SIZE AND TYPE	C	AN..35
8077	SHIPPER SUPPLIED EQUIPMENT INDICATOR, CODED	C	AN..3
8249	EQUIPMENT STATUS, CODED	C	AN..3
8169	FULL/EMPTY INDICATOR, CODED	C	AN..3

FTX FREE TEXT

To provide free form or coded text information.

4451	TEXT SUBJECT QUALIFIER	M	AN..3
4453	TEXT FUNCTION, CODED	C	AN..3
C107	TEXT REFERENCE	C	
4441	FREE TEXT, CODED	M	AN..3
1131	CODE LIST QUALIFIER	C	AN..3
3055	CODE LIST RESPONSIBLE AGENCY, CODED	C	AN..3
C108	TEXT LITERAL	C	
4440	FREE TEXT	M	AN..70
4440	FREE TEXT	C	AN..70
4440	FREE TEXT	C	AN..70
4440	FREE TEXT	C	AN..70
4440	FREE TEXT	C	AN..70
3453	LANGUAGE, CODED	C	AN..3

GDS NATURE OF CARGO

To indicate the type of cargo as a general classification.

C703	NATURE OF CARGO	C	
7085	NATURE OF CARGO, CODED	M	AN..3
1131	CODE LIST QUALIFIER	C	AN..3
3055	CODE LIST RESPONSIBLE AGENCY, CODED	C	AN..3

GID GOODS ITEM DETAILS

To indicate totals of a goods item.

1496	GOODS ITEM NUMBER	C	N..5
C213	NUMBER AND TYPE OF PACKAGES	C	
7224	NUMBER OF PACKAGES	M	N..8
7065	TYPE OF PACKAGES IDENTIFICATION	C	AN..17
1131	CODE LIST QUALIFIER	C	AN..3
3055	CODE LIST RESPONSIBLE AGENCY, CODED	C	AN..3
7064	TYPE OF PACKAGES	C	AN..35
C213	NUMBER AND TYPE OF PACKAGES	C	
7224	NUMBER OF PACKAGES	M	N..8
7065	TYPE OF PACKAGES IDENTIFICATION	C	AN..17
1131	CODE LIST QUALIFIER	C	AN..3
3055	CODE LIST RESPONSIBLE AGENCY, CODED	C	AN..3
7064	TYPE OF PACKAGES	C	AN..35
C213	NUMBER AND TYPE OF PACKAGES	C	
7224	NUMBER OF PACKAGES	M	N..8
7065	TYPE OF PACKAGES IDENTIFICATION	C	AN..17
1131	CODE LIST QUALIFIER	C	AN..3
3055	CODE LIST RESPONSIBLE AGENCY, CODED	C	AN..3
7064	TYPE OF PACKAGES	C	AN..35

HAN HANDLING INSTRUCTIONS

To specify handling and where necessary, notify hazards.

C524	HANDLING INSTRUCTION	C	
4079	HANDLING INSTRUCTIONS, CODED	C	AN..3
1131	CODE LIST QUALIFIER	C	AN..3
3055	CODE LIST RESPONSIBLE AGENCY, CODED	C	AN..3
4078	HANDLING INSTRUCTIONS	C	AN..70
C218	HAZARDOUS MATERIAL	C	
7419	HAZARDOUS MATERIAL CLASS CODE, IDENTIFICATION	C	AN..4
1131	CODE LIST QUALIFIER	C	AN..3
3055	CODE LIST RESPONSIBLE AGENCY, CODED	C	AN..3

LOC PLACE/LOCATION IDENTIFICATION

To identify a country/place/location/related location one
related location two.

3227	PLACE/LOCATION QUALIFIER	M	AN..3
C517	LOCATION IDENTIFICATION	C	
3225	PLACE/LOCATION IDENTIFICATION	C	AN..25
1131	CODE LIST QUALIFIER	C	AN..3
3055	CODE LIST RESPONSIBLE AGENCY, CODED	C	AN..3
3224	PLACE/LOCATION	C	AN..17
C519	RELATED LOCATION ONE IDENTIFICATION	C	
3223	RELATED PLACE/LOCATION ONE IDENTIFICATION	C	AN..25
1131	CODE LIST QUALIFIER	C	AN..3
3055	CODE LIST RESPONSIBLE AGENCY, CODED	C	AN..3
3222	RELATED PLACE/LOCATION ONE	C	AN..70
C553	RELATED LOCATION TWO IDENTIFICATION	C	
3233	RELATED PLACE/LOCATION TWO IDENTIFICATION	C	AN..25
1131	CODE LIST QUALIFIER	C	AN..3
3055	CODE LIST RESPONSIBLE AGENCY, CODED	C	AN..3
3232	RELATED PLACE/LOCATION TWO	C	AN..70
5479	RELATION, CODED	C	AN..3

MEA MEASUREMENTS

To specify physical measurements, including dimension
tolerances, weights and counts.

6311	MEASUREMENT APPLICATION QUALIFIER	M	AN..3
C502	MEASUREMENT DETAILS	C	
6313	MEASUREMENT DIMENSION, CODED	C	AN..3
6321	MEASUREMENT SIGNIFICANCE, CODED	C	AN..3
6155	MEASUREMENT ATTRIBUTE, CODED	C	AN..3
6154	MEASUREMENT ATTRIBUTE	C	AN..70
C174	VALUE/RANGE	C	
6411	MEASURE UNIT QUALIFIER	M	AN..3
6314	MEASUREMENT VALUE	C	N..18
6162	RANGE MINIMUM	C	N..18
6152	RANGE MAXIMUM	C	N..18
6432	SIGNIFICANT DIGITS	C	N..2
7383	SURFACE/LAYER INDICATOR, CODED	C	AN..3

NAD NAME AND ADDRESS

To specify the name/address and their related function,
either by C082 only and/or unstructured by C058 or structured
by C080 thru 3207.

3035	PARTY QUALIFIER	M	AN..3
C082	PARTY IDENTIFICATION DETAILS	C	
3039	PARTY ID IDENTIFICATION	M	AN..35
1131	CODE LIST QUALIFIER	C	AN..3
3055	CODE LIST RESPONSIBLE AGENCY, CODED	C	AN..3
C058	NAME & ADDRESS	C	
3124	NAME AND ADDRESS LINE	M	AN..35
3124	NAME AND ADDRESS LINE	C	AN..35
3124	NAME AND ADDRESS LINE	C	AN..35
3124	NAME AND ADDRESS LINE	C	AN..35
3124	NAME AND ADDRESS LINE	C	AN..35
C080	PARTY NAME	C	
3036	PARTY NAME	M	AN..35
3036	PARTY NAME	C	AN..35
3036	PARTY NAME	C	AN..35
3036	PARTY NAME	C	AN..35
3036	PARTY NAME	C	AN..35
3045	PARTY NAME FORMAT, CODED	C	AN..3
C059	STREET	C	
3042	STREET AND NUMBER/P.O.BOX	M	AN..35
3042	STREET AND NUMBER/P.O.BOX	C	AN..35
3042	STREET AND NUMBER/P.O.BOX	C	AN..35
3164	CITY NAME	C	AN..35
3229	COUNTRY SUB-ENTITY IDENTIFICATION	C	AN..9
3251	POSTCODE IDENTIFICATION	C	AN..9
3207	COUNTRY, CODED	C	AN..3

RFF REFERENCE

To specify a reference.

C506	REFERENCE	M
1153	REFERENCE QUALIFIER	M AN..3
1154	REFERENCE NUMBER	C AN..35
1156	LINE NUMBER	C AN..6
4000	REFERENCE VERSION NUMBER	C AN..35

RNG RANGE DETAILS

To identify a range.

6167	RANGE TYPE QUALIFIER	M AN..3
C280	RANGE	C
6411	MEASURE UNIT QUALIFIER	M AN..3
6162	RANGE MINIMUM	C N..18
6152	RANGE MAXIMUM	C N..18

TDT DETAILS OF TRANSPORT

To specify mode and means of transport.

8051	TRANSPORT STAGE QUALIFIER	M	AN..3
8028	CONVEYANCE REFERENCE NUMBER	C	AN..17
C220	MODE OF TRANSPORT	C	
8067	MODE OF TRANSPORT, CODED	C	AN..3
8066	MODE OF TRANSPORT	C	AN..17
C228	TRANSPORT MEANS	C	
8179	TYPE OF MEANS OF TRANSPORT IDENTIFICATION	C	AN..8
8178	TYPE OF MEANS OF TRANSPORT	C	AN..17
C040	CARRIER	C	
3127	CARRIER IDENTIFICATION	C	AN..17
1131	CODE LIST QUALIFIER	C	AN..3
3055	CODE LIST RESPONSIBLE AGENCY, CODED	C	AN..3
3128	CARRIER NAME	C	AN..35
8101	TRANSIT DIRECTION, CODED	C	AN..3
C401	EXCESS TRANSPORTATION INFORMATION	C	
8457	EXCESS TRANSPORTATION REASON, CODED	M	AN..3
8459	EXCESS TRANSPORTATION RESPONSIBILITY, CODED	M	AN..3
7130	CUSTOMER AUTHORIZATION NUMBER	C	AN..17
C222	TRANSPORT IDENTIFICATION	C	
8213	ID OF MEANS OF TRANSPORT IDENTIFICATION	C	AN..9
1131	CODE LIST QUALIFIER	C	AN..3
3055	CODE LIST RESPONSIBLE AGENCY, CODED	C	AN..3
8212	ID OF MEANS OF TRANSPORT	C	AN..35
8453	NATIONALITY OF MEANS OF TRANSPORT, CODED	C	AN..3
8281	TRANSPORT OWNERSHIP, CODED	C	AN..3

TMP TEMPERATURE

To specify the temperature range and/or setting.

6245	TEMPERATURE QUALIFIER	M	AN..3
C239	TEMPERATURE SETTING	C	
6246	TEMPERATURE SETTING	C	N3
6411	MEASURE UNIT QUALIFIER	C	AN..3

UNB INTERCHANGE HEADER

To start, identify and specify an interchange.

S001	SYNTAX IDENTIFIER	M	
0001	SYNTAX IDENTIFIER	M	A4
0002	SYNTAX VERSION NUMBER	M	N1
S002	INTERCHANGE SENDER	M	
0004	SENDER IDENTIFICATION	M	AN..35
0007	PARTNER IDENTIFICATION CODE QUALIFIER	C	AN..4
0008	ADDRESS FOR REVERSE ROUTING	C	AN..14
S003	INTERCHANGE RECIPIENT	M	
0010	RECIPIENT IDENTIFICATION	M	AN..35
0007	PARTNER IDENTIFICATION CODE QUALIFIER	C	AN..4
0014	ROUTING ADDRESS	C	AN..14
S004	DATE/TIME OF PREPARATION	M	
0017	DATE OF PREPARATION	M	N6
0019	TIME OF PREPARATION	M	N4
0020	INTERCHANGE CONTROL REFERENCE	M	AN..14
S005	RECIPIENTS REFERENCE PASSWORD	C	
0022	RECIPIENT'S REFERENCE/PASSWORD	M	AN..14
0025	RECIPIENT'S REFERENCE/PASSWORD QUALIFIER	C	AN2
0026	APPLICATION REFERENCE	C	AN..14
0029	PROCESSING PRIORITY CODE	C	A1
0031	ACKNOWLEDGEMENT REQUEST	C	N1
0032	COMMUNICATIONS AGREEMENT ID	C	AN..35
0035	TEST INDICATOR	C	N1

UNH MESSAGE HEADER

To head, identify and specify a message.

0062	MESSAGE REFERENCE NUMBER	M	AN..14	
S009	MESSAGE IDENTIFIER	M		
0065	MESSAGE TYPE IDENTIFIER	M	AN..6	
0052	MESSAGE TYPE VERSION NUMBER	M	AN..3	
0054	MESSAGE TYPE RELEASE NUMBER	M	AN..3	
0051	CONTROLLING AGENCY	M	AN..2	
0057	ASSOCIATION ASSIGNED CODE	C	AN..6	
0068	COMMON ACCESS REFERENCE	C	AN..35	
S010	STATUS OF THE TRANSFER	C		
0070	SEQUENCE MESSAGE TRANSFER NUMBER	M	N..2	
0073	FIRST/LAST SEQUENCE MESSAGE TRANSFER INDICATION	C		A1

UNT MESSAGE TRAILER

To end and check the completeness of a message.

0074	NUMBER OF SEGMENTS IN A MESSAGE	M	N..6	
0062	MESSAGE REFERENCE NUMBER	M	AN..14	

UNZ INTERCHANGE TRAILER

To end and check the completeness of an interchange.

0036	INTERCHANGE CONTROL COUNT	M	N..6	
0020	INTERCHANGE CONTROL REFERENCE	M	AN..14	

10. SMDG EDI-ELECTRONIC DATA INTERCHANGE UNDERSTANDING

This draft is the result of work carried out by a SMDG-Subgroup. It was set up mainly on TEDIS drafts (May 1991/January 1994) but ideas and comments of EDI Council of Canada, American Bar Association, UN/ECE Recommendations and German DIN also were taken into account. So - in general - this draft can be seen as a globally oriented Understanding.

Version 1

September 1994

SMDG EDI-ELECTRONIC DATA INTERCHANGE UNDERSTANDING**Introduction**

The terms and conditions of this Understanding which can be used in bilateral or multilateral EDI relationships shall govern the conduct and methods of operation between the Parties in relation to the interchange of data by teletransmission for the purpose of or associated with the supply of vessel, inland carriers and container related data. They take account of the Uniform Rules of Conduct for Interchange of Trade Data by Teletransmission as adopted by the International Chamber of Commerce and in conjunction with the TEDIS Programme European Model EDI Agreement. The Understanding is considered to be a contractual framework setting out intentions and clarifying rights and obligations. If necessary additional rules might be agreed between Parties, these rules are specific/bilateral and can be worked out in an appendix. Parties in this Understanding are:

Shipping Lines; Agents; Container Terminals; Stevedores, Inland Carriers, etc.
(Detail of the parties: see enclosure A)

SMDG EDI-ELECTRONIC DATA INTERCHANGE UNDERSTANDING**1. Definitions**

For the purposes of the EDI Understanding the following definitions shall apply:

Acknowledgment of Receipt:

A message acknowledging or rejecting, with error indication, a received interchange, a functional group or a message.

Message verification

Message verification includes the identification, authentication and verification of the integrity and origin of a message by use of an authentication mechanism such as a digital signature and/or any alternative security means or procedures to establish that a message is genuine.

Adopted protocol

An accepted method for the interchange of messages based on the UN/EDIFACT standard (agreed version) for the presentation and structuring of the transmission of messages, or such other protocol as may be agreed in writing by the Parties.

Data Transfer

One or more EDI-messages sent together as one unit of transmission, which includes the heading and termination data in accordance with UN/EDIFACT.

Days

Any day.

Data Log

The complete historical and chronological record of interchanged data representing the messages interchanged between the Parties.

EDI

Electronic Data Interchange is the transmission of data structured according to agreed message standards, between information systems, by electronic means.

EDI message

A coherent set of data, structured according to agreed message standards, for transmission by electronic means, prepared in a computer readable format and capable of being automatically and unambiguously processed.

Technical Annex (see enclosure B)

The Technical Annex consists of:

User manual (for example for BAPLIE, MOVINS, TANSTA), a handbook with message specifications as descriptions of data elements, segments, and data structures.

Technical specifications as systems operation, methods of transmission, third Party providers.

Procedural/organisational rules: E.g. the communication pattern between a stowage Centre and a member of related container terminals; acknowledgement of receipt, message verification.

UN/EDIFACT

The United Nations rules for Electronic Data Interchange for Administration, Commerce and Transport, comprising a set of internationally agreed standards, directories and guidelines for the electronic interchange of structured data, and in particular, interchange related to trade and goods and services, between independent and computerised information systems.

SMDG EDI-ELECTRONIC DATA INTERCHANGE UNDERSTANDING**2. Object and Scope**

The provisions contained in this EDI Understanding shall govern the exchange of EDI messages between named Parties.

The provision of the Technical Annex form an integral part of the EDI Understanding. Accordingly, the breach of any of the provisions contained within the Technical Annex shall be a breach of the EDI Understanding itself.

When Parties mutually agree in writing upon additional provisions to this Understanding, such provisions shall form an integral part of this Understanding.

Parties agree that all EDI Messages shall be transmitted in accordance with the provisions of the adopted protocol for Data Interchange, as specified in the Technical Annex.

3. Applicability

The Container Handling Agreement covers all contingencies not covered and/or addressed in this EDI Understanding. In case of non conformity of this EDI Understanding and the Container Handling Agreement, this EDI Understanding shall prevail in respect of data interchange only.

4. Operational Requirements for EDI**4.1 Message Standards**

All EDI messages shall be transmitted in accordance with the UN/EDIFACT standards (EDIFACT syntax rules ISO 9735, latest version) and recommendations and their updated versions, as approved and published by the United Nations Economic Commission for Europe (UN/ECE) in the United Nations Trade Data Interchange Directory (UNTDID), details of which are set out in the technical annex - part USER MANUAL.

4.2 Systems Operation

The Parties shall provide and maintain, to the level specified in the Technical Annex, the equipment (hardware), software and services necessary to effectively transmit, receive, log and store EDI messages.

4.3 Method of Transmission

The Parties shall agree between themselves a method of transmission and, if required, use the services of Third Party Network Providers.

4.4 Specifications

All specifications and details regarding 4.1., 4.2., and 4.3., shall be as set out in the Technical Annex.

The Parties shall conduct such tests as may be mutually defined from time to time to establish and monitor the adequacy of the standards, hardware, software, protocols, services or any of the relevant specifications for the purpose of this Understanding.

SMDG EDI-ELECTRONIC DATA INTERCHANGE UNDERSTANDING**5. Acknowledgement of Receipt of EDI Messages**

5.1 In addition to the acknowledgements included in the telecommunication protocols, the Parties may agree that the receiver of an EDI Message sends an acknowledgement of receipt of the message. Alternatively the Parties may define in the Technical Annex, the extent to which any messages sent and received will be subject to an acknowledgement of receipt. A message to be acknowledged must not be acted upon before complying with the request for an acknowledgement.

5.2 If Parties mutually agree upon an acknowledgement of receipt this acknowledgement of receipt of an EDI message shall be send in such time as is defined in the Technical Annex. In the event that no specific time limits have been agreed or stated in the Technical Annex, the acknowledgement shall be send within one working day following the day of receipt of the EDI message to be acknowledged.

5.3 If the sender does not receive the acknowledgement of receipt within the time limit, he may, upon giving notification to the receiver to that effect, treat the Message as null and void as from the expiration of that time limit or initiative an alternative recovery procedure as specified in the Technical Annex, to ensure effective receipt of the acknowledgement.

In case of failure of recovery procedure, within the time limit, the Message will definitely be treated as null and void, as from the expiration of that time limit, upon notification to the receiver.

6. Processing of EDI Messages

The Parties undertake to process or ensure their system processes the EDI messages within any time limits specified in the Technical Annex, or as agreed between the Parties, or in the absence of such, as soon as possible.

7. Security of EDI Messages

The Parties will only be responsible and liable for breaking the rules of verification, identification and authentication in case of gross negligence or wilful misconduct.

7.1 The Parties undertake to implement and maintain control and security procedures and measures necessary to ensure the protection of messages against the risk of unauthorized access, loss or destruction.

7.2 In addition to the elements of control relevant for EDI messages provided by the UN/EDIFACT rules, the Parties shall agree on procedures or methods to ensure message verification. The specifications relating to the message verification should be set out in the Technical Annex.

When message verification results in the rejection of, or the detection of an error in an EDI message, the receiver will inform the sender thereof within the time limits specified in the Technical Annex or agreed between the Parties, provided the sender is identified, and will not act upon the message before receiving instructions to do so, from the sender.

If a sender of an EDI Message includes non modified data from a previous EDI Message into a new EDI Message, the sender is not liable for the completeness and accuracy of this non-modified data.

7.3 For security purposes, the Parties may agree to use a specific form of protection for certain messages such as a method of encryption or any other method agreed between the Parties, as long as it is permitted by law. The same method shall be respected for any subsequent transmissions or re-transmissions of a protected message.

SMDG EDI-ELECTRONIC DATA INTERCHANGE UNDERSTANDING

8. Confidentiality

The Parties shall ensure that messages containing information specified to be confidential by the sender or agreed to be confidential between the Parties, are maintained in confidence and are not disclosed or transmitted to any unauthorised persons nor used for any purposes other than those intended by the Parties.

Messages shall not be regarded as containing confidential information to the extent that such information is legitimately in the public domain.

The same degree of confidentiality as specified, in this clause, shall be respected on any authorised disclosure to another person.

9. Force Majeure

A Party shall not be deemed to be in breach of this Understanding or otherwise be liable to any other Party, by reason of any delay in performance, or non-performance, of any of its obligations hereunder to the extent that such delay or non-performance is due to any Force Majeure of which he has immediately notified such other Party; and the time for performance of that obligation shall be extended accordingly. Any cause of this delay shall in so far as possible be remedied with all reasonable dispatch. However, should the extended time for performance that one of the parties is rendered unable by force majeure to carry out its obligations under this Understanding, exceed . . . days, the other party it entitled to terminate this Understanding without costs.

10. Default

Upon becoming aware of any circumstances resulting in failure, delay or error in performing its obligations, each Party shall immediately inform the other Party(ies) hereto and use their best endeavours to communicate by alternative means.

Any planned non - availability of either Party's interchange facility must be reported 48 hours in advance to the other Party.

11. Logging, Recording, and Storage of EDI Messages

11.1 Each Party will keep, a data log, to store all EDI Messages. These shall be stored by the sender in the transmitted format and by the receiver in the format in which they are received.

11.2 The data log shall be maintained unaltered and securely for such time as agreed between the Parties

11.3 In addition to any relevant national legislative or regulatory requirements, when the data log is maintained in the form of electronic or computer records, the Parties shall ensure that the recorded EDI messages are readily accessible and that they can be reproduced in a readable form and, if required, can be printed.

SMDG EDI-ELECTRONIC DATA INTERCHANGE UNDERSTANDING**12. Intermediaries**

12.1 If a Party uses the services of an intermediary in order to transmit, log or process EDI Messages, that Party shall be responsible towards the other Party or Parties for any acts, failures or omissions of the intermediary not being wilful misconduct or gross negligence as though they were his own acts, failures or omissions and for the purposes of this understanding, the intermediary shall be deemed to be acting on behalf of that Party.

12.2 If a Party instructs any other Party to use the services of an intermediary for transmitting, logging or processing EDI messages then the instructing Party shall be responsible towards the other Party for such intermediary's acts, failures or omissions.

12.3 Parties shall ensure that it is a contractual responsibility of the intermediary that no change is made to the substantive data content of the EDI messages to be re-transmitted and that such EDI messages are not disclosed to any unauthorized person.

12.4 In case of wilful misconduct of said intermediary, such intermediary shall be liable against his principle for his acts failures or omissions.

13. Electronic Transactions

13.1 The Parties accept that operational instructions and/or operational data are validly formed by exchange of EDI messages, and expressly waive any rights to bring an action declaring the invalidity of a transaction concluded between themselves on the sole ground that the transaction took place by use of EDI.

13.2 Unless otherwise agreed, operational instructions and/or operational data made by EDI will be considered to be concluded at the time and the place where the EDI Message constituting the acceptance of these instructions and data is made available to the information systems of the receiver.

14. Admissibility in evidence Messages

To the extent permitted by law, the parties hereby agree that in the event of dispute, the records of Messages, which they have maintained in accordance with the terms of this Understanding, shall be admissible before the Courts and shall constitute evidence of the facts contained therein unless evidence to the contrary is adduced.

15. Liability

Each Party shall be liable for any direct damage arising from or as a result of any breach of this Understanding or any failure, delay or error in sending, receiving or acting on any message. The liability is restricted to any direct damages resulting from wilful acts or gross negligence. Neither Party shall be liable to the other for any consequential damages, including loss of profit, arising directly or indirectly from or as a result of any such breach, failure, delay or error.

The Parties acknowledge that the use of EDI Messages is to their mutual benefit; the information obtained by each Party about the affairs of the other following the negotiations and performance of this Understanding shall not be used to impose liability for consequential damages or in any other way to increase the

liability of either Party in the event of a failure to perform its obligations under this Contract, beyond what it would have incurred for a breach of the Container Handling Agreement.

16. Interpretation of the User Manual

Any question relating to the interpretation of the User manual as part of the Technical Annex may be referred by the Parties to the body responsible for the publication of the User Manual or the relevant Working Group within the SMDG (Shipplanning Message Development Group) as may be applicable acting as experts and not arbitrators. The arbitrators' decision shall be final and binding on the Parties making the reference.

17. Costs

The Parties agree that transfer costs of EDI Messages will be specified and become part of the Technical Annex.

18. Applicable Law and Arbitration

The applicable law governing the Understanding shall , in all respect, be (name of Country; completed by the Parties) law and shall be referred to arbitration in

The competent Civil Courts of shall have jurisdiction.

In the event of a conflict between the law of any contract being effected by EDI and the Understanding the law of the contract will prevail.

Any dispute arising in connection with the provisions of this Understanding shall be settled by negotiations between the Parties. If unsuccessful, and unless otherwise agreed, the dispute should be settled by such arbitration as the Parties may decide.

19. Effects, Term and Severability

This Understanding shall be effective from the date on which it is signed.

Any Party may terminate this Understanding by giving not less than one month's notice either by registered post or by any other means agreed between the Parties. The notice shall indicate the date when the Understanding will cease. Termination of the Understanding shall only affect transactions after that date.

Notwithstanding termination for any reason, the rights and obligations of the Parties referred to in clauses 6, 7, 8, 11 and 15, shall survive termination.

20. Amendments in Writing

Any terms agreed between the Parties as additions or amendments to this Understanding, shall only be valid if they are set out in the Technical Annex or are otherwise in writing and signed by the Parties.

September 1994

Enclosure A (SMDG EDI-ELECTRONIC DATA INTERCHANGE UNDERSTANDING)

An Understanding made this day of 19

by and between

.....
.....
.....

hereinafter referred to as "the Line" on the one part,

and

.....
.....

hereinafter referred to as "TERMINAL" on the other part.

WHEREAS the parties hereto are desirous to agree on methods of operation between them in relation to the interchange of data by teletransmission for the purpose of or associated with containerrelated activities under the Container Handling Agreement between THE TERMINAL and the Line dated, under reference number (hereinafter referred to as "the Understanding";

WHEREAS the parties hereto wish to establish the terms and conditions under which such interchange of data by teletransmission shall take place;

NOW THEREFORE THE PARTIES HERETO AGREE AS FOLLOWS:

Enclosure B (SMDG EDI-ELECTRONIC DATA INTERCHANGE UNDERSTANDING)**Technical Annex**

The technical annex consists of :

- User manuals
- Technical specifications
- Procedural/organisational rules

Items to be specified

0.Communication pattern

1.Documents, messages, directories, codes, syntax, segments, data elements, design guide-lines, implementation guide-lines

2.EDP-System

- equipment/hardware
- software
- services

3.Transmission, Methods of Communication

- protocol
- network
- platform
- sequences
- responsibility (sender/receiver)

4.Time

- working time
- time limits for . . .

5.Acknowledgement

- kinds of A.
- time limits for A.

6.Responsibilities

...

7.Intermediaries

- names
- contracts

8.Storage

- kinds of St.
- time/limits/periods

9.Securities

APPENDIX B (Contd) (SMDG EDI-ELECTRONIC DATA INTERCHANGE UNDERSTANDING)

10.Procedures for tests and trials

11.Backup/Disaster Recovery

12.Costs

13.Limits of Responsibility and Liability

14.Special conditions/Exceptions

15.Modifications

16.Others