

# **Report of GME in Washington DC.**

**Yoshi Kito**

**EDI Standardisation Expert**

**4<sup>th</sup> May, 2011, Hamburg**

**GME: Global meeting of Experts on Trade Facilitation Recommendations  
and Electronic Business Standards**

# Agenda

1. **DMRs for TPFREP (item 7)**
2. **Report UN/Recommendation #23 + #16  
(item11)**
3. **Report DMRs from SMDG, COXXX messages,  
Vent Seals (item 12)**
4. **TBG3 Activities in Washington (item 13)**



USER GROUP FOR SHIPPING LINES AND CONTAINER TERMINALS

# Agenda

## 1. DMRs for TPFREP (item 7)

# **DMRs from TBG3**

## **1. SMDG**

**From Michael: 18**

**From Yoshi: 9**

**From Marcelo: 1**

## **2. France (Urban Logistics Project)**

**From Marielle: 26**

## **3. TBG3 secretary (24 hours rules in EU)**

**From Henk: 3**

# Result of assessment

<b>1. Approved</b>	<b>19</b>
<b>2. JT</b>	<b>31</b>
<b>3. Rejected</b>	<b>1</b>
<b>4. <u>Withdrawn</u></b>	<b>6</b>
<b>Total</b>	<b>57</b>

**JT: Approved with a minor change(s)**

# Details of assessment (TPFREP)

Message ID	Requirements	De No.	Requested code Name	Result
TPFREP	Message structure change			A
TPFREP	New code request	2005	Unmooring, date and time	A
TPFREP	New code request	2005	First Crane Lift	JT
TPFREP	New code request	2005	Last Crane Lift	JT
TPFREP	New code request	6063	Number of container moves, load and discharge	A
TPFREP	New code request	6063	Number of containers to be shifted	A
TPFREP	New code request	6063	Number of Ro/Ro container moves, load and discharge	A
TPFREP	New code request	6063	Number of Ro/Ro moves of units, load and discharge	JT
TPFREP	New code request	6063	Number of breakbulk cargo items, load and discharge	JT
TPFREP	New code request	6063	Number of stacking frames, load and discharge	JT
TPFREP	New code request	6063	Number of containers discharged for restow	A
TPFREP	New code request	6063	Number of containers loaded for restow	A
TPFREP	New code request	6063	Number of hatch cover moves	JT
TPFREP	New code request	6063	Total number of equipment moves, load and discharge	JT
TPFREP	New code request	8053	Container gantry crane	JT
TPFREP	New code request	8053	Mobile crane	JT
TPFREP	New code request	8053	Floating crane	JT
TPFREP	New code request	8053	Ship's equipment crane	JT

# Agenda

## 2. Report UN/Recommendation #23 + #16 (item11)

# A new code request (UN/Recommendation #23)

UN FREIGHT COST CODES Revision 8

(UN/ECE CEFACT Trade Facilitation Recommendation No.23)

C l	Gro up	Subgro up	Det ail	Description	Mode/Site Indicator	Duplicate Indicator
+	2	09	015	Bundling of flatracks		

- The above is requested by ECT
- ICG at the GME approved the above code.
- The final approval will be done at the next UN/CEFACT Plenary on June.
- The above code is used for INVOIC message.



# **UN/LOCODE**

## **(UN/Recommendation #16)**

- 1. Important code of ports & inland points for SMDG members.**
- 2. Code list is published twice a year (latest version 2010-2).**
- 3. About 65.500 location codes are included in the code list.**
- 4. How to maintain & upgrade the quality of the code.**

# DMR procedure in Japan

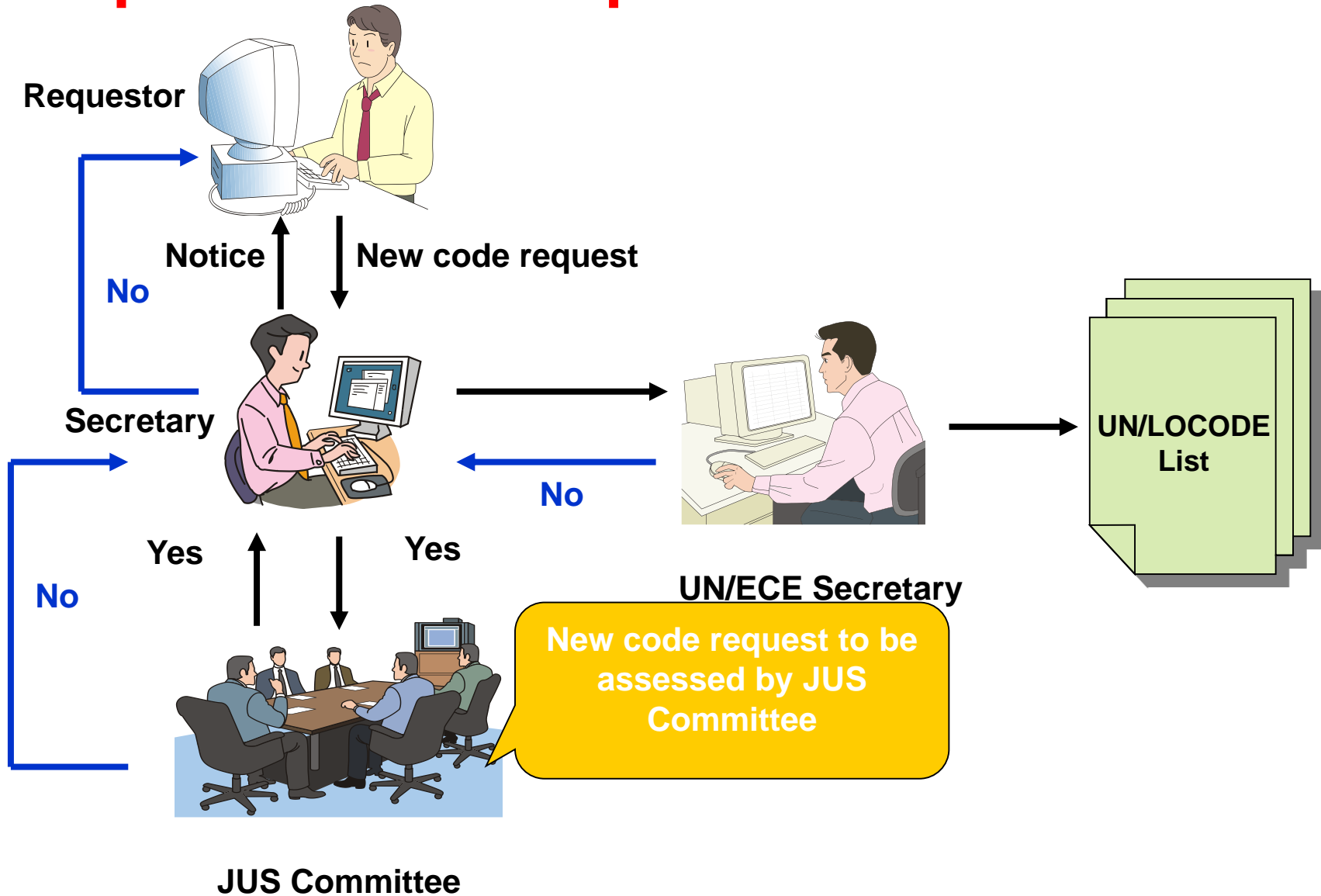

# New entry on the website (1)



**UNECE** United Nations Economic Commission for Europe

HOME PROGRAMMES MEETINGS INFORMATION RESOURCES ABOUT UNECE CONTACT UNECE

## UN/LOCODE Menu

Main menu  
Online help  
Logout

### Quick links

[UN/LOCODE code list](#)  
[UNEDOCS](#)  
[UN/CEFACT](#)  
[UN/MEDIFACT](#)

## UN/LOCODE Entry Request System - Request for new entry

User name: jast *Requestor details:* [Edit](#)  
Japan Association for simplification of international trade procedures [Contact name: Hiroshi Kohno]  
Address: 104-0032 Yaesu No,5 Nagaoka Bldg, 2-29-11, Hatchobori Chuo-ku Tokyo, Japan  
E-mail ID: h-kohno@jastpro.or.jp | Phone: +81335556063 | Fax: +81335556032

Please read below new rules for submission of requests  
<http://apps.unece.org/unlocode>

Country*	<input type="text" value="- Select -"/>
Location name*	<input type="text"/> (Local name in Latin characters, including any diacritical marks)
Check UN/LOCODE entries	<input type="button" value="Check"/>
Subdivision*	<input type="text"/> If you don't know please select "Not known "
UN/LOCODE	<input type="text"/> <input type="text"/> (Two-letter country code, plus proposed three-letter code for location name)



# Issues

1. Automatically added into the next UN/LOCODE Directory without any assessment in a national assessment committee
2. No national assessment organisations without few countries
3. Plan to re-establish an UN/LOCODE working group under UN/CEFACT so as to maintain & upgrade the code quality

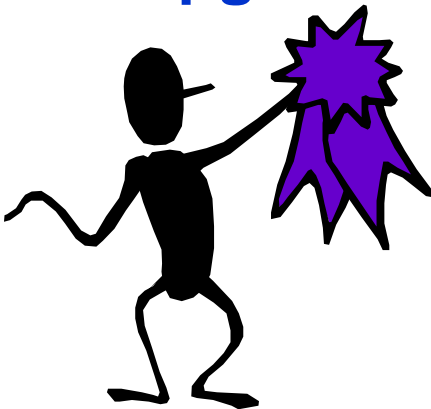

# Agenda

3. Report DMRs from SMDG, COXXX messages,  
Vent Seals (item 12)



USER GROUP FOR SHIPPING LINES AND CONTAINER TERMINALS

# Message structure change of COXXXX

## Current

## Amended

Example: COARRI

0510	SG 12 TDT-LOC-DTM	C	9	0510	SG 12 TDT-SG13		
0520	TDT	M	1	0520	TDT	M	1
0530	LOC	C	9	0530	SG13 LOC-DTM	C	9
0540	DTM	C	9	0550	LOC	M	1
				0560	DTM	C	9

### Reason:

The relation is not clear between LOC & DTM.

**SMDG agreed to amend all message structure at the last meeting to adopt the above within the TDT segment group.**



## Details of assessment (COXXX)

Message ID	Requirements	De No.	Requested code Name	Result
COREOR	Change description			A
CODECO	Change description			A
COPARN	Change description			JT
CODENO	Change description			A
COPINO	Change description			A
COARRI	Change description			Rejected
COHAOR	Change description			JT
COPRAR	Change description			A
COARRI	Message structure change			JT
CODECO	New code request	4525	Air fresh vent seal	JT

## Details of assessment (Air fresh vent seal)

Message ID	Seg Gr.No.	De No.	Requested code Name	Result
CODECO	New code request	4525	Air fresh vent seal	JT

### Further action:

Develop a new version of MIG of CODECO based on D.11A for MSC do Brasil.



USER GROUP FOR SHIPPING LINES AND CONTAINER TERMINALS

# Agenda

## 4. TBG3 Activities of in Washington (item 13)



# **TBG3**

## **Transport and Logistics**

**Chair: Dominique Vankemmel, France**

**Vice Chair: Yoshi Kito, Japan**

**Vice Chair: Simon Spoormaker, Netherlands**

**Secretary: Henk Van Maaren, Netherlands**

***Liaisons : ISO/TCs 104,154,204 & 8, ANSI X12I, WCO***



# TBG3

- Future organization of UN/CEFACT: active participation in brainstorming sessions and TBG StC.
- Strong requirement expressed by TBG3: our group representing a Business domain must keep its integrity and unity, for visibility to the outside world and to our sponsors
- “Advance Cargo Declaration” (Security of freight): productive joint session with TBG4/WCO and TBG15.
- 57 DMRs processed by ATG during the week (among total 100) for Urban Logistics (sustainable development ) and Maritime (SMDG)
- Next TBG3 interim meetings: Berlin 20-24 June 2011 and Valencia 14-18 November 2011
- Follow-up on projects, especially Cargo Tracing Tracking with TBG4



# Re-organisation of UN/CEFACT

(The common understanding\_1)

## Current

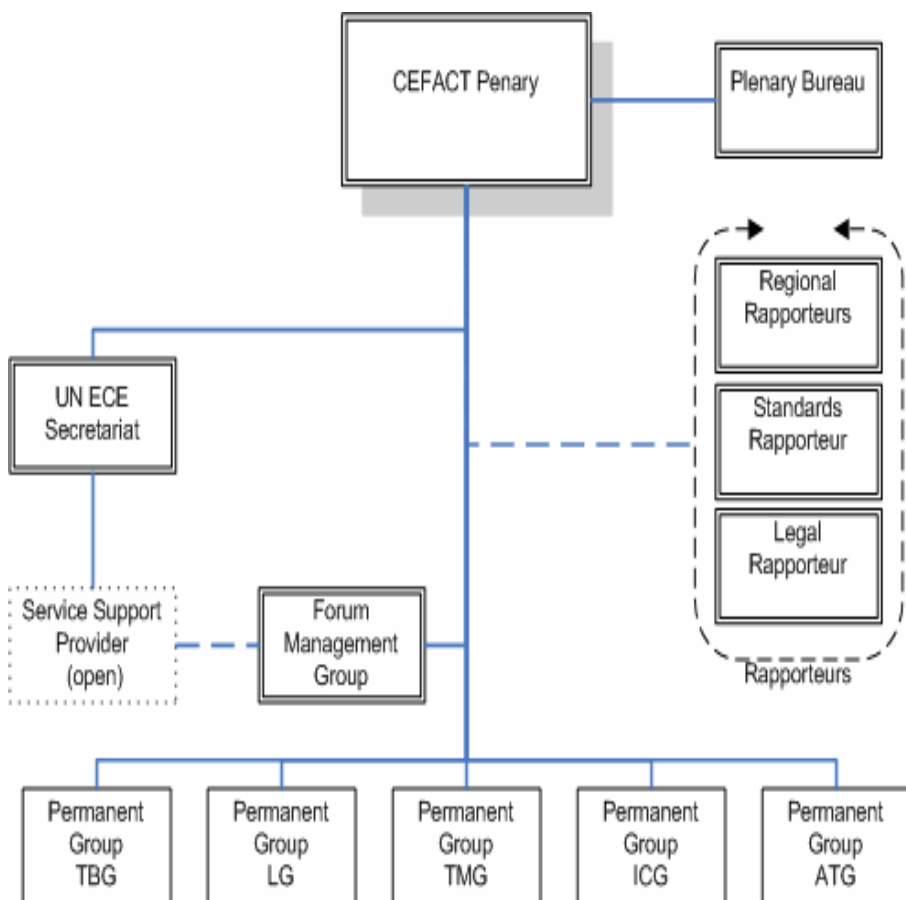

## Future

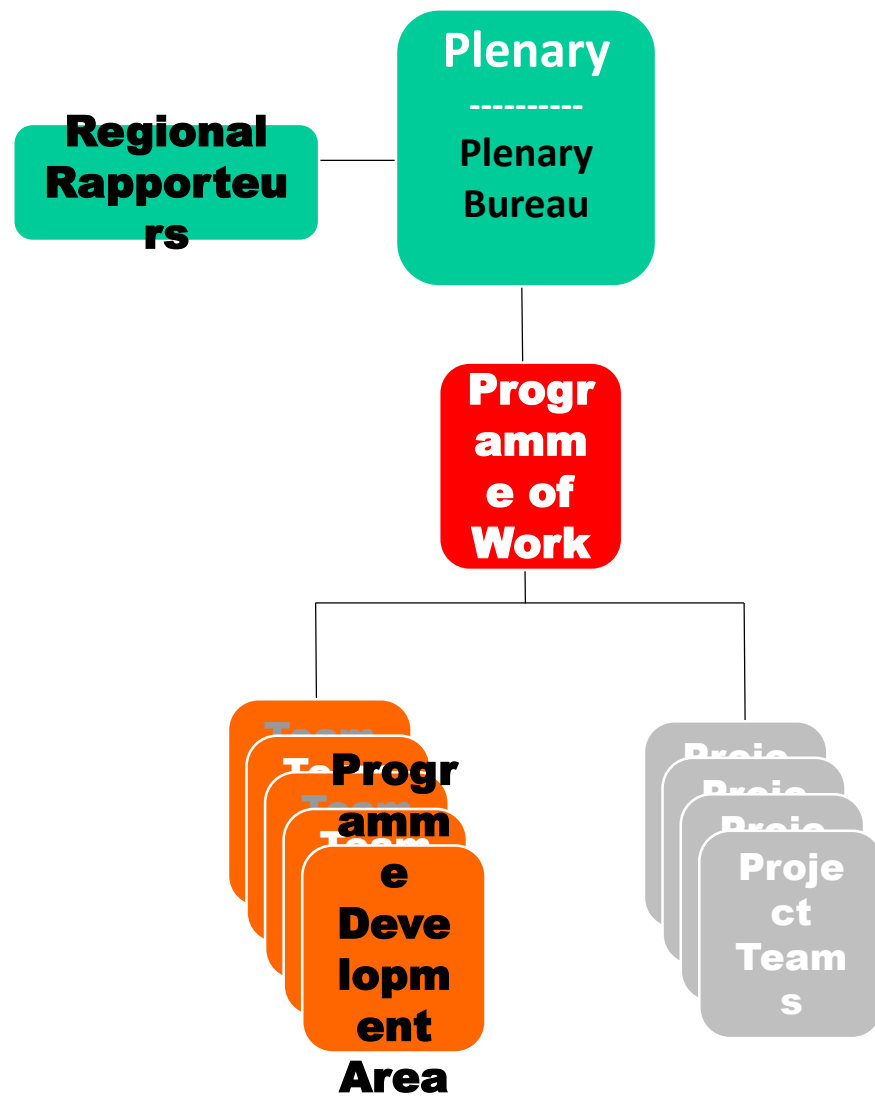



USER GROUP FOR SHIPPING LINES AND CONTAINER TERMINALS

# Re-organisation of UN/CEFACT

## (The common understanding\_2)

Stakeholders: parties interested in using and/or developing UN/CEFACT's recommendations and standards.

Bureau Vice Chairs: elected by the Plenary for a three-year term and are responsible for activities of Programme Development Areas, related Projects and other designated Bureau functions.

Programme Development Area: a grouping of Domain Experts, that prepares the groundwork for the programme of work, by identifying strategic requirements of stakeholders, formulating coherent sets of related project proposals, monitoring ongoing progress of current projects and requests for maintenance of recommendations and standards. Bureau Vice Chairs are responsible for the activities of the Programme Development Area in collaboration with Domain Coordinators.

Programme of Work: the UN/CEFACT Plenary-approved set of activities for a two-year period, most importantly with respect to projects.



USER GROUP FOR SHIPPING LINES AND CONTAINER TERMINALS

# Re-organisation of UN/CEFACT

## (The common understanding\_3)

**Project proposal** : articulate one or more deliverables, conformant with the approved Programme of Work, that will follow the UN/CEFACT Open Development Process. Project proposals may be submitted to the Bureau by a Plenary Delegation, an existing Project teams or a member of Bureau. Experts may develop Project proposals in Programme Development Areas for subsequent submission by their Bureau Vice Chair(s).

**Projects**: develop and update recommendations and standards as well as other deliverables (e.g. implementation guides or reference models), subject to Open Development Process. Project, which conform to the Programme of Work, can be approved by the Bureau to proceed.

**Programme Development Area**: Responsible for project, regularly report progress to the Bureau Vice Chair of the designated Programme Development Area and informs interested Domain Coordinators. Appointment of the project leader is confirmed by the Bureau.

**Experts**: nominated by Plenary Heads of Delegation, experts have business and/or technical competency and are registered in the Roster of Experts. Information about experts will only appear on the UN/CEFACT website subject to their approval.





# Re-organisation of UN/CEFACT

(The common understanding\_4)

## Open Development Process

Project Inception

Requirements gathering

Draft development

Public Draft Review

Project Exit

Publication

Maintenance



# Scenario 1



USER GROUP FOR SHIPPING LINES AND CONTAINER TERMINALS

## List of Domains (areas of expertise within UN/CEFACT)

### Business

- Accounting & Audit
- Agriculture
- Architecture, Engineering & Construction
- Customs
- Environmental Management
- Finance/Payments
- Government
- Health Care
- Insurance
- International Trade Procedures
- Manufacturing
- Procurement
- Statistics
- Supply Chain Management
- Transport
- Travel/Tourism
- Technological
- Audit
- Business
- Process Analysis
- Harmonization

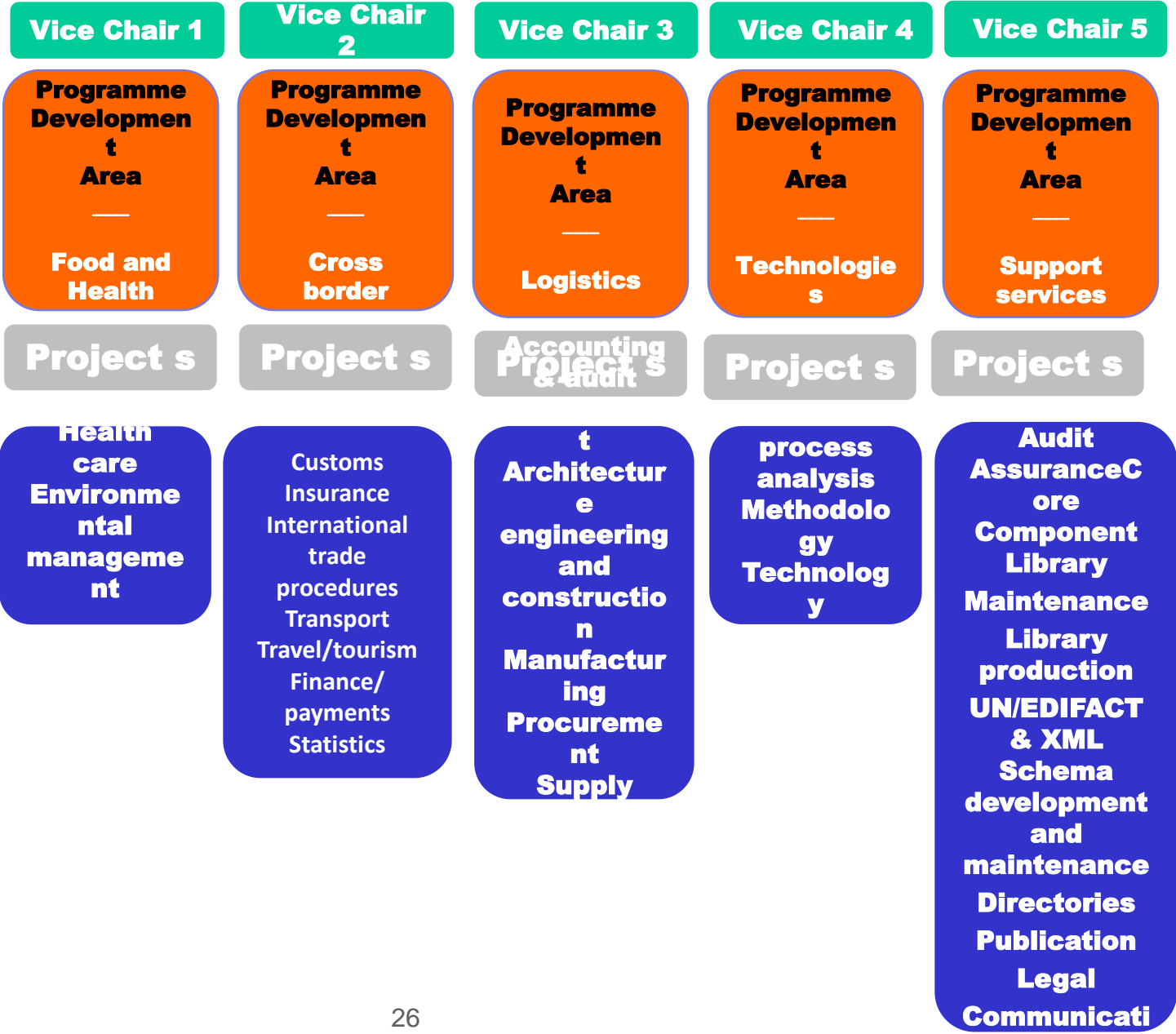

# Scenario 2

UN/Cefact  
Plenary



UN/Cefact  
Bureau



UN/Cefact  
Forum  
Plenary

MINALS

PDA  
Cross-sectorial

**Programme Development  
Areas and Projects**

PDA9: Support Group—  
Publication Process

—  
Harmonization of Core  
Components  
QA & Processes & Edifact  
directories  
Publication  
Entry Point

Development Areas : for  
instance eProcurement...

**Publication**

- Recommendations
- Data and Messages  
Standards
- Design and Syntactical  
Standards

**Project  
Teams**

**Project  
Teams**

**Project  
Teams**

PDA10  
Support Groups—  
Methodology and Tool

—  
Tools list  
Experts list  
Methodology and Design  
Audit Methodology  
Legal

PDA  
Sectorial

PDA5: Tourisme and Leisure  
PDA6: Environmental  
Management  
PDA7: Agriculture  
PDA8: eGovernment

**Project  
Teams**

PDA11  
Support Group—  
Promotion

—  
Web for Standards  
Training and Webinars  
eMagazine

**Domain Coordinators:  
Banking, Custom, Healthcare**

**Any Questions**

**?**

**Thank you for your attention**